



**1-3.5 ton
ENGINE POWERED
FORKLIFT**



**h2000
SERIES** **Reliable forklift**

HELI

CHINESE EXPORT BRAND

Recommended
By China Chamber of Commerce for Import and Export of Machinery
And Electric Products



ENGINE POWERED
FORKLIFT

13.5 ton

h2000
SERIES

Reliable forklift

A reliable Drive system



As the most reliable transmission system produced by HELI, it has been validated by over twenty years' experience in World market. Meanwhile, various ancillary devices of the power system ensure the reliability effectively.

- ✓ The mean time between failures for transmission is 8000 hours.
- ✓ Equipped with the intake system & intake silencer
- ✓ Optional air filter pressure alarm device
- ✓ Automatic engine preheating system
- ✓ Cyclone Air Filter
- ✓ Lost foam casting
- ✓ Various high-power engines are available for customers' optional choices, and the emission meets the latest European & American environmental regulation.

A reliable mast



The high internal-qualified mast confirmedly ensures the safety of the operator, truck and cargo. Standard configuration of the wide-view mast enlarges operators' view effectively, and ensures loading /unloading operations more reliable.

- ✓ Using the best German steel material for triplex mast (option only for triplex mast)
- ✓ The frame of mast has more strength basing on the enlarged channel interface.
- ✓ Clear visibility for standard wide-view mast
- ✓ The channel with own patented technology has the first-rate quality.

Comfortable operation space

The capacious operating space together with the enormous ergonomic-design and configuration ensure the operation more comfortable & convenient, and effectively enhance the efficiency & safety of operation.

- ✓ Filled with noise-reducing and buffer rubber material between bonnet and frameworks
- ✓ Newly patented insulation materials of Bonnet
- ✓ Well-designed non-slip mat
- ✓ Special display with easily reading
- ✓ Standard files packet
- ✓ Exhaust system is flexibly connected with the frame.

A reliable hydraulic system

HELI has the most professional R&D base of cylinders, where we take advantage of the advanced manufacturing technologies and detecting means to ensure the reliability of all cylinders of the hydraulic system.

- ✓ Standard tilt cylinder by HELI
- ✓ Standard lift cylinder by HELI
- ✓ Standard steering cylinder by HELI
- ✓ Self-locking tilt cylinder
- ✓ Standard hydraulic circuit filter
- ✓ Speed-controlling function on lifting system



A reliable steering system

The steering system with new technologies not only provides a smoother swerve and faster positioning & steering, but also effectively ensures operators' safety.



- ✓ Smaller turning radius
- ✓ Wearable tire
- ✓ Full hydraulic power steering





ENGINE POWERED
FORKLIFT

1.3.5 ton



Manufacturers Data and Design Characteristics

Characteristics																														
1	Manufacturer	HELI																												
2	Model	CPC10	CPD10	CPC15	CPD15	CPC18	CPD18	CPC20	CPD20	CPC25	CPD25	CPC30	CPD30	CPC35	CPD35	CPQ10	CPQD10	CPQ15	CPQD15	CPQ18	CPQD18	CPQ20	CPQD20	CPQ25	CPQD25	CPQ30	CPQD30	CPQ35	CPQD35	
3	Power unit	Diesel										Gasoline																		
4	Rated Capacity	kg	1000	1500	1750	2000	2500	3000	3500	1000	1500	1750	2000	2500	3000	3500														
5	Load Center	mm	500																											
6	Operation	Driver seated										Driver seated																		
Dimensions																														
7	Overall max.lifting height (with backrest ,unladen)	h4	mm	4008	4005	4005	3995	3995	4227	4222	4008	4005	4005	3995	3995	4227	4222													
8	Max.Lifting height	h3	mm	3000			3000			3000			3000																	
9	Height mast retracted(upright)	h1	mm	1995	1995	1995	2000	2000	2070	2180	1995	1995	1995	1995	1995	2070	2180													
10	Free lift height	h2	mm	150	155	155	170	170	160	170	150	155	155	170	170	160	170													
11	Backrest height(from upper face of forks)	h8	mm	1008	1005	1005	995	995	1227	1222	1008	1005	1005	1005	995	1227	1222													
12	Overhead Guard clearance(from face of seat)	h7	mm	1025			1035			1025			1035																	
13	Overall height(overhead guard)	h6	mm	2070	2070	2070	2070	2070	2090	2090	2070	2070	2070	2070	2070	2090	2090													
14	Overall length(with forks)	L1	mm	2941	3165	3213	3442	3667	3772	3783	2941	3165	3213	3442	3667	3772	3783													
15	Overall length(without forks)	L2	mm	2171	2245	2293	2522	2597	2702	2713	2171	2245	2293	2522	2597	2702	2713													
16	Front overhang	X	mm	421	425	428	482	482	487	498	421	425	428	482	482	487	498													
17	Rear overhang	L4	mm	350	420	465	440	515	515	515	350	420	465	440	515	515	515													
18	Wheel base	L5	mm	1400	1400	1400	1600	1600	1700	1700	1400	1400	1400	1600	1600	1700	1700													
19	Coupler height	h5	mm	250	250	250	290	290	310	310	250	250	250	290	290	310	310													
20	Min.ground clearance under mast	m1	mm	110	110	110	110	110	135	135	110	110	110	110	110	135	135													
21	Overall width	B	mm	1070	1070	1070	1150	1150	1225	1225	1070	1070	1070	1150	1150	1225	1225													
22	Lateral fork adjustment outside of fork(Max./Min.)	R	mm	950/200			1000/222	1000/222	1055/250	1055/250	950/200			1000/222	1000/222	1055/250	1055/250													
23	Tread(front)	S	mm	890	890	920	970	970	1000	1000	890	890	920	970	970	1000	1000													
24	Tread(rear)	P	mm	920	920	920	970	970	970	970	920	920	920	970	970	970	970													
25	Outside turning radius	Wa	mm	1880	1955	1985	2170	2170	2420	2400	1880	1955	1985	2170	2240	2400	2420													
26	Inside turning radius	v	mm	110	110	95	160	160	200	200	110	110	95	160	160	200	200													
27	Min.intersecting aisle	Ra	mm	1977	2052	2093	2200	2280	2380	2400	1977	2052	2093	2200	2280	2380	2400													
28	Tilting angles(forward/backward)	α/β		6° /12°			6° /12°			6° /12°			6° /12°																	
29	Fork dimensions(axbxc)	mm		770×100×32	920×100×35	920×100×35	920×100×45	1070×100×45	1070×125×45	1070×125×50	770×100×32	920×100×35	920×100×35	920×100×45	1070×100×45	1070×125×45	1070×125×50													
Performance																														
30	Max. Traveling speeds(With/Without load)	km/h		13.5/14.5			17/19			18/19			19/19			13.5/14.5			17/19			18/19			19/19					
31	Lifting Speeds(With/Without load)	mm/s		590/650			530/550			440/480			330/370			590/650			530/550			450/480			310/340					
32	Lowering Speeds(With/Without load)	mm/s		450/550			450/550			450/500			350/400			450/550			450/550			450/500			350/400					
33	Max. Draw-bar pull,(With/Without load)	kN	12.3/7	18/7	12.3/7	18/7	12.3/7	18/7	14.2/9	16.4/9	13.7/8.6	16.2/8.6	13.5/9.8	16/9.8	16.7/11.8	20.6/11.8	9.3/6.9	14.2/6.9	9.3/6.9	14.2/6.9	9.3/6.9	14.2/6.9	11/9	12.3/9	9.8/8.6	12.3/8.6	9.1/9.8	10.8/9.8	14/9.8	18.5/9.8
34	Max. Negotiable Gradient(With/Without load)	%		≥20			23/20	25/20	20/17	21.5/17	15/17	16/17	20/15	22/15	30/22	37/22	23/18	27/18	20/17	24/17	18/20	18/20	15/17	15/17	12/14	14/14	15/15	15/15		
Weights																														
35	Service Mass	kg	2220	2660	2890	3320	3680	4270	4700	2220	2660	2890	3320	3680	4270	4700														
36	Load Wheel with load(Front/Rear)	kg	2830/390	3640/520	4040/600	4788/532	5562/618	6543/727	7380/820	2830/390	3640/520	4040/600	4788/532	5562/618	6543/727	7380/820														
37	Load Wheel without load(Front/Rear)	kg	1220/1000	1170/1490	1140/1750	1328/1992	1472/2208	1708/2562	1880/2820	1220/1000	1170/1490	1140/1750	1328/1992	1472/2208	1708/2562	1880/2820														
Tyres																														
38	Wheels number front/rear(x=driven)		2X/2			2X/2			2X/2			2X/2																		
39	Tyre Type		Pneumatic			Pneumatic			Pneumatic			Pneumatic																		
40	Tyre size(front)		6.50-10-10PR			7.00-12-12PR			28×9-15-12PR			28×9-15-14PR																		
41	Tyre size(rear)		5.00-8-8PR			6.00-9-10PR			6.50-10-10PR			6.50-10-10PR																		
42	Service Brake		Hydraulic-Foot Pedal										Hydraulic-Foot Pedal																	
43	Parking Brake		Mechanical-Hand Lever										Mechanical-Hand Lever																	
Drive																														
44	Battery (Voltage/Capacity)	V/Ah	12/80			12/80			12/60			12/60																		
45	Internal Combustion Engine Model		Kubota V2403			Kubota V2403			Kubota V3600			NISSAN K15			NISSAN K21			NISSAN K25												
46	Internal Combustion Engine Rated Output	kW/rpm	35.4/2400			35.4/2400			36.5/2600			46.9/2400			23.6/2400			31.2/2250			37.6/2400									
47	Internal Combustion Engine Rated Torque	Nm/rpm	161.3/1600			161.3/1600			164/1500			210/1600			103/1600			143.7/1600			176.5/1600									
48	Internal Combustion Engine Number of Cylinder		4-87×102.4			4-87×102.4			4-98×120			4-75.5×83			4-89×83			4-89×100												
49	Internal Combustion Engine Displacement	L	2.434			2.434			3.62			1.468			2.065			2.488												
50	Internal Combustion Engine Fuel Tank Capacity	L	38			60			38			60																		
51	Transmission Number of Speed Fwd/Bwd type		1-1Power Shift T/M, 2-2 Manual Shift T/M			1-1Power Shift T/M, 2-2 Manual Shift T/M			1-1Power Shift T/M, 2-2 Manual Shift T/M			1-1Power Shift T/M, 2-2 Manual Shift T/M																		

Reliable special designed instrument

The reliable special instrument gives a complete display of the vital information, like operation status, fault detection, etc. It ensures the operator predominate the vehicle status more intuitive and convenient.

- ✓ Stepping motor core
- ✓ Programmable LCD
- ✓ Electrical safety standard meets CE requirements

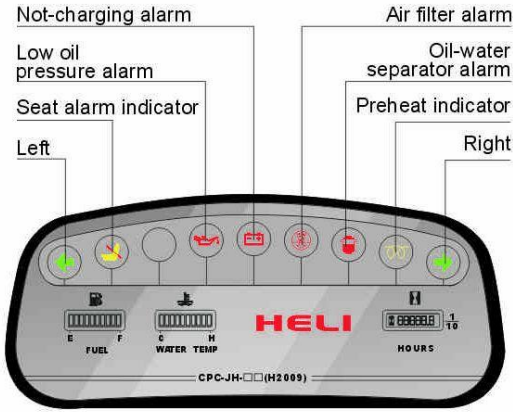

Standard

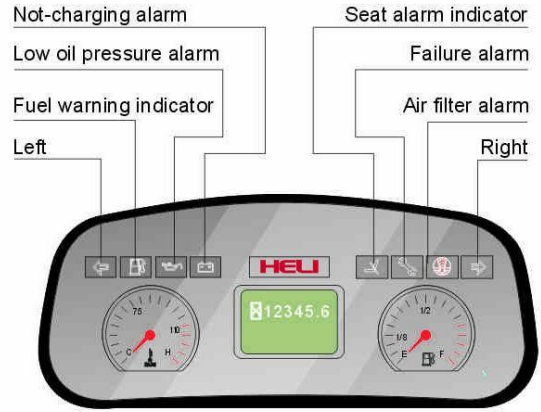

With PSI motor

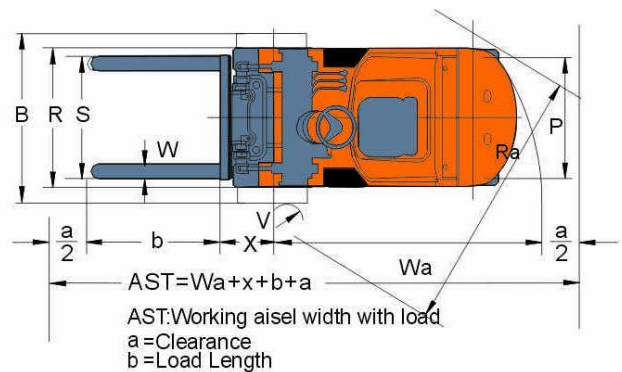
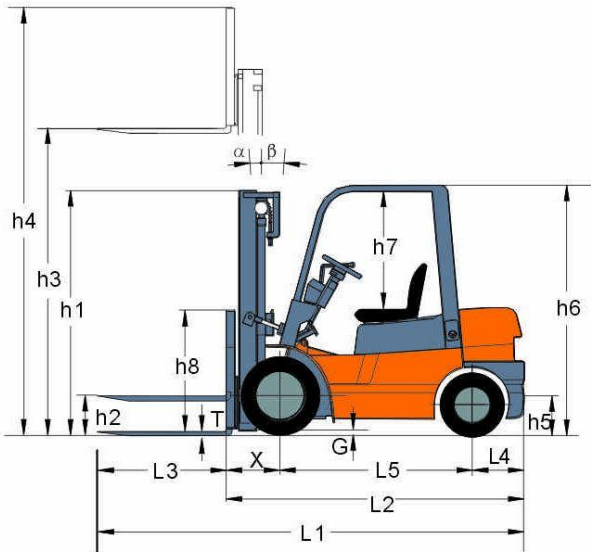

GROUND CLEARANCE	2t/2.5t	3t
Drive Axle	135	140
Steer Axle	150	150
Counter Weight	140	155
Frame	120	130

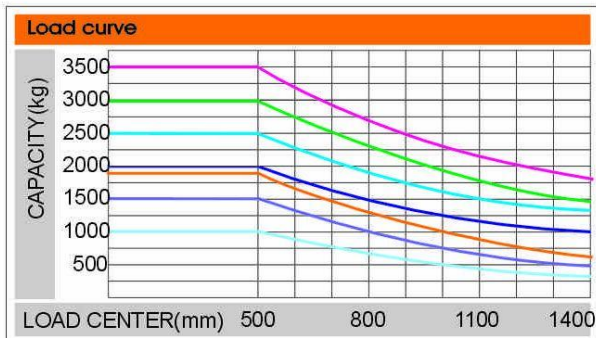

- CPC20/CPD20
CPQD20/CP(Q)YD20
- CPC26/CPD26
CPQD26/CP(Q)YD26
- CPC30/CPD30
CPQD30/CP(Q)YD30
- CPC35/CPD35
CPQD35/CP(Q)YD35
- CPC18/CPD18
CPQ18/CPQD18
- CPC15/CPD15
CPQ15/CPQD15
- CPC19/CPD19
CPQ19/CPQD19

Note:

Capacities shown are computed with upright in vertical position, based on a 1000 mm cube load configuration with the center of gravity at the true center of the cube, and standard forks. Truck capacities with upright in forward tilt position will be less. Long forks, and unusually wide or loads may also reduce capacity.

Reliable forklift



1-3.5t WIDE VIEW MAST

Mast model	Max. fork height mm	Capacity at 500mm; Load center (kg)								Overall Mast Height (mm)					Tilting Angle	Service Weight (kg)						
		CPQ10/ CPQD10/ CPQD10	CPQ15/ CPQD15/ CPQD15	CPQ18/ CPQD18/ CPQD18	CPQ20/ CPQD20/ CPQD20	CPQ25/ CPQD25/ CPQD25	CPQ30/ CPQD30/ CPQD30	CPQ35/ CPQD35/ CPQD35	At Lowered				Lift (with Backrest)	CPQ10/ CPQD10/ CPQD10		CPQ15/ CPQD15/ CPQD15	CPQ18/ CPQD18/ CPQD18	CPQ20/ CPQD20/ CPQD20	CPQ25/ CPQD25/ CPQD25	CPQ30/ CPQD30/ CPQD30	CPQ35/ CPQD35/ CPQD35	
									1-1.8t	2-2.5t	3t	3.5t										1-1.8t
M200	2000	1000	1500	1750	2000	2500	3000	3500	1495	1500	1565	1680	3030	6-12	2120	2530	2760	3240	3600	4265	4800	
M250	2500	1000	1500	1750	2000	2500	3000	3500	1745	1750	1815	1930	3530	6-12	2145	2555	2785	3280	3640	4310	4850	
M300	3000	1000	1500	1750	2000	2500	3000	3500	1995	2000	2065	2180	4030	6-12	2180	2590	2820	3320	3680	4355	4900	
M330	3300	1000	1500	1750	2000	2500	3000	3500	2145	2155	2215	2330	4330	6-12	2195	2605	2835	3345	3705	4375	4935	
M350	3500	1000	1500	1750	2000	2500	3000	3500	2245	2255	2315	2430	4530	6-12	2210	2620	2850	3360	3720	4390	4935	
M370	3700	1000	1500	1750	2000	2500	3000	3500	2345	2355	2415	2530	4730	6-6 6-12	2230	2640	2870	3375	3735	4410	4970	
M400	4000	1000	1500	1750	2000	2500	3000	3500	2545	2555	2615	2730	5030	6-6 6-12	2270	2680	2910	3420	3780	4470	5055	
M425	4250	950	1400	1650	1900	2250	2650	3150	2670	2675	2740	2855	5280	6-6 6-12	2285	2695	2925	3440	3800	4490	5085	
M450	4500	950	1350	1550	1800	2150	2750	3000	2795	2800	2865	2980	5530	6-6 6-12	2300	2710	2940	3460	3820	4510	5100	
M500	5000	930	1000	1100	1600	1650	2400	2500	3045	3050	3115	3230	6030	6-6 6-6	2335	2745	2975	3500	3860	4560	5170	
M550	5500	*900	*1150	*1500	*1600	*1950	*2400	*2500	3345	3350	3415	3530	6530	*3-6	2500	2910	3140	3695	4055	4780	5270	
M600	6000	*850	*1050	*1400	*1500	*1800	*2200	*2300	3595	3600	3665	3780	7030	*3-6	2530	2940	3170	3735	4095	4820	5330	

NOTE: (1) For gas, diesel model: +90kg, dual wheels weight: +110kg.
 (2) *(Front wheel) is dual wheels load capacity.
 (3) Rated capacity with (*) shows capacity with front dual tires.
 (4) Max lifting without lift-bracket: -470mm.

1-3.5t WIDE VIEW FULL FREE 2-STAGE MAST

Mast model	Max. fork height mm	Capacity at 500mm; Load center (kg)								Overall Mast Height (mm) At Lowered				Free Lift (with Backrest)				Tilting Angle	Service Weight (kg)						
		CPQ10/ CPQD10/ CPQD10	CPQ15/ CPQD15/ CPQD15	CPQ18/ CPQD18/ CPQD18	CPQ20/ CPQD20/ CPQD20	CPQ25/ CPQD25/ CPQD25	CPQ30/ CPQD30/ CPQD30	CPQ35/ CPQD35/ CPQD35	At Lowered				1-1.8t	2-2.5t	3t	3.5t	CPQ10/ CPQD10/ CPQD10		CPQ15/ CPQD15/ CPQD15	CPQ18/ CPQD18/ CPQD18	CPQ20/ CPQD20/ CPQD20	CPQ25/ CPQD25/ CPQD25	CPQ30/ CPQD30/ CPQD30	CPQ35/ CPQD35/ CPQD35	
									1-1.8t	2-2.5t	3t	3.5t													
ZM200	2000	1000	1500	1750	2000	2500	3000	3500	1535	1495	1570	1680	490	495	350	560	6-12	2135	2555	2795	3250	3615	4290	4830	
ZM250	2500	1000	1500	1750	2000	2500	3000	3500	1745	1745	1820	1930	735	745	600	710	6-12	2195	2615	2855	3340	3680	4360	4880	
ZM300	3000	1000	1500	1750	2000	2500	3000	3500	1995	1995	2070	2180	965	965	850	960	6-12	2230	2650	2890	3385	3725	4390	4930	
ZM330	3300	1000	1500	1750	2000	2500	3000	3500	2145	2145	2220	2330	1135	1145	1000	1100	6-12	2250	2670	2910	3405	3750	4415	4965	
ZM350	3500	1000	1500	1750	2000	2500	3000	3500	2245	2245	2320	2430	1235	1245	1100	1210	6-12	2265	2685	2925	3420	3765	4460	5000	
ZM370	3700	1000	1500	1750	2000	2500	3000	3500	2370	2370	2420	2530	1360	1370	1215	1335	6-6 6-12	2280	2700	2940	3375	3735	4410	5000	
ZM400	4000	1000	1500	1750	2000	2500	3000	3500	2545	2545	2620	2730	1535	1545	1400	1510	6-6 6-12	2330	2750	2990	3500	3840	4545	5085	
ZM425	4250	950	*1400	*1500	*1900	*2200	*2650	*3000	2670	2670	2745	2855	1660	1670	1525	1635	6-6 6-12	2350	2770	3010	3525	3865	4565	5115	
ZM450	4500	950	*1400	*1700	*1900	*2400	*3000	*3000	2795	2795	2870	2980	1785	1795	1650	1760	6-6 6-12	2365	2785	3025	3545	3880	4595	5130	
ZM500	5000	930	1000	1100	1600	1650	2400	2500	3045	3045	3120	3230	2035	2045	1920	2010	6-6 6-6	2400	2820	3060	3590	3925	4615	5200	
ZM550	5500	*900	*1350	*1600	*1700	*2200	*2850	*2850	3345	3345	3420	3530	2335	2345	2200	2310	*3-6	2575	2995	3235	3790	4120	4875	5300	
ZM600	6000	*850	*1050	*1400	*1500	*1800	*2200	*2300	3595	3595	3670	3780	2585	2595	2450	2560	*3-6	2610	3030	3270	3835	4170	4920	5360	

NOTE: (1) 2-2.5t free lift height (without backrest): +435mm, 3t free lift height (without backrest): +580mm.
 (2) Dual wheels weight: +110kg.
 (3) *(front wheel) is dual wheels load capacity.
 (4) Max lifting height without bracket: -470mm.
 (5) Free lifting height without bracket: +470mm.
 (6) Rated capacity with (*) shows capacity with front dual tires.

1-3.5t WIDE VIEW FULL FREE 3-STAGE MAST

Mast model	Max. fork height mm	Capacity at 500mm; Load center (kg)								Overall Mast Height (mm) At Lowered				Free Lift (with Backrest)				Tilting Angle	Service Weight (kg)						
		CPQ10/ CPQD10/ CPQD10	CPQ15/ CPQD15/ CPQD15	CPQ18/ CPQD18/ CPQD18	CPQ20/ CPQD20/ CPQD20	CPQ25/ CPQD25/ CPQD25	CPQ30/ CPQD30/ CPQD30	CPQ35/ CPQD35/ CPQD35	At Lowered				1-1.8t	2-2.5t	3t	3.5t	CPQ10/ CPQD10/ CPQD10		CPQ15/ CPQD15/ CPQD15	CPQ18/ CPQD18/ CPQD18	CPQ20/ CPQD20/ CPQD20	CPQ25/ CPQD25/ CPQD25	CPQ30/ CPQD30/ CPQD30	CPQ35/ CPQD35/ CPQD35	
									1-1.8t	2-2.5t	3t	3.5t													
ZSM360	3600	1000	1450	1750	2000	2400	2900	3300	1790	1795	1945	1985	750	755	670	710	6-6 6-6	2275	2695	2935	3470	3810	4580	-	
ZSM400	4000	1000	1400	1600	1900	2400	2900	3300	1920	1920	2065	2115	880	880	795	845	6-6 6-6	2300	2720	2960	3505	3845	4615	-	
ZSM430	4350	900	*1350	*1550	*1850	*2200	*2650	*3000	2040	2045	2190	2240	1000	1005	920	970	6-6 6-6	2325	2745	2985	3535	3885	4650	5075	
ZSM450	4500	900	1300	1500	1700	2150	2700	2900	2090	2095	2240	2340	1050	1050	970	1070	6-6 6-6	2355	2750	2995	3565	3910	4660	5080	
ZSM470	4700	900	*1350	*1450	*1720	*2000	*2550	*2800	2160	2160	2240	-	1120	1120	970	-	6-6 6-6	2365	2760	3005	3565	3910	4660	-	
ZSM480	4800	900	*1250	*1400	*1700	*1950	*2500	*2800	2190	2195	2340	2440	1150	1155	1070	1170	6-6 6-6	2375	2775	3010	3575	3915	4680	5095	
ZSM500	5000	900	1100	1150	1600	1650	2400	2400	2290	2295	2440	2565	1250	1255	1170	1295	6-6 6-6	2400	2780	3035	3715	4055	4725	5085	
ZSM540	5400	750	*850	*850	*1450	*1500	*2250	*2300	2420	2420	2565	2665	1380	1380	1295	1395	3-6 3-6	2420	2815	3055	3895	4235	4760	-	
ZSM600	6000	*850	*1100	*1400	*1600	*1800	*2100	*2200	2650	2655	2790	2885	1610	1605	1520	1615	3-6 3-6	2480	2875	3115	3945	4285	4850	-	
ZSM650	6500	*800	*1000	*1250	-	-	-	-	2855	-	-	-	1815	-	-	-	*3-6	2530	2925	3165	-	-	-	-	
ZSM700	7000	-	-	*850	*1000	*1200	*1500	-	3025	3031	3175	-	1985	1990	1906	-	*3-6	2580	2975	3215	4345	4485	5250	-	

NOTE: (1) 2-2.5t free lift height (without backrest): +435mm, 3t free lift height (without backrest): +580mm.
 (2) Dual wheels weight: +110kg.
 (3) *(front wheel) is dual wheels load capacity.
 (4) Max lifting height without bracket: -470mm.
 (5) Free lifting height without bracket: +470mm.
 (6) Rated capacity with (*) shows capacity with front dual tires.

HELI

h2000
SERIES

Reliable forklift



1-3.5 ton
**ENGINE POWERED
FORKLIFT**

STANDARD EQUIPMENT

Handle
Neutral Switch
Tools
Hour Metr
Side Roller
Electric Horn
Standard Seat
Fuel Gauge
Standard Fork
Drawbar Pin
Fuel Regulator
Overhead Guard
Parking Break
Back-Up Alarm
Rear View Mirror
Wide View Mast
Lamp Bracket
Loading Bracket
Charge Indicator
Wearable Tire
Radiator Reserve
Engine Glow Indicator

Class II (III) Carriage
Overhead Air Intake
Overhead Guard Canvas
Return Hydraulic Filter
Dipstick For Tor-Con Oil
Deluxe Rubber Floor Mat
Two-Spool Control Valve
Dipstick for hydraulic oil
Rear Combination Lamp
Transmission Filter
Anti-Lock Valve For Tilting
Ignition Key Engine Stop
Engine Auto Glow System
Shock absorber For Hook
Water temperature gauge
Front Combination Lamp
Full Hydraulic Power Steering
Tilt adjustable steering column
Lifting & Tilting Control Lever
Engine Oil Pressure Indicator
Toggle Type Parking Break Lever

OPTIONS

Heater
Windshield
Power Clutch
Rear View Mirror
Fire Extinguisher
Catalytic Muffler
Suspension Seat
Rear Working Light
Dual Air Cleaner
Overhead Exhaust System
Custom Color Paint
Steel Mesh For Protection
Solid / Pneumatic Tire
Dual Drive Wheel With Fender
Spark Arrester Muffler
Auxiliary Hydraulic Valve Modules
Tilt Seat For LPG Forklift
LPG Fuel System
Oil Temperature Gauge For Torque Converter
Boot For Tilt Cylinder and Steering Cylinder
Cyclone Air Cleaner



TOP1 FORKLIFT MANUFACTURING AND SALE
IN CHINA CONTINUOUSLY FOR 20 YEARS



Jl. Inspeksi Kalimalang KM. 22 Blok A Gudang A-01, Cibuntu, Bekasi - 17530

Telp : +628195555969

Email : thubastunggalperkasa@gmail.com

Website : www.thubastunggalperkasa.co.id