

The reliable special instrument gives a complete display of the vital information, like operation status, fault detection, etc. It ensures the operator predominate the vehicle status more intuitive and convenient.

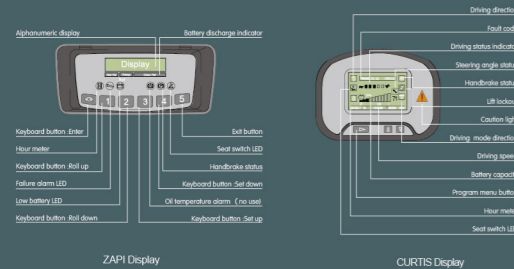

Standard configuration	Optional device
wide view basic mast	slings rod
standard fork	driver's cab
II (III) stage fork arm carrier	lifting hook
backrest	cargo boom
control valve	tip-over fork
battery	back view mirror
standard seat	side shifting
overhead guard	paper roll clamp
overhead guard rain cover	warning light (Flashing - rotating - buzzing)
liquid crystal combined instrument	solid tyre
pneumatic tyre	rear working light
traction pin	steel protection net
driver's tool	multipurpose drum clamp
LED Lamp	load stabilizer
Horn alert function on rear handle	widen fork arm carrier
	lengthening fork
	load pusher
	lengthening fork extension
	rotating flat clamp
	widen tyre protection device
	auxiliary hydraulic valve component
	tilting/steering cylinder jacket
	coloring tyre
	wide view two/three stage full free mast
	customer made color
	Turn automatic deceleration function
	Battery lifting sling

**HELI** 安徽合力股份有限公司  
 ANHUI HELI CO., LTD.

THUBAS TUNGGAL PERKASA  
 PT. THUBAS TUNGGAL PERKASA

Jl. Inspeksi Kalimantan KM. 22 Blok A Gudang A-01, Cibuntu, Bekasi - 17530  
 Telp : (021) 8953 5873  
 Mobile : +62 819 555 5969  
 Email : thubastunggalperkasa@gmail.com  
 Website : www.thubastunggalperkasa.co.id



**1-2.5 t H3 series AC Electric Forklift Truck**

**H3 series** | HIGH EFFICIENCY ENERGY SAVING

**HELI**  
 LIFTING THE FUTURE

**25 YEARS** TOP1 FORKLIFT MANUFACTURER AND SALES IN CHINA FOR CONSECUTIVE 25 YEARS

**H3 1-2.5t** H3 series AC Electric Forklift Truck

**H3 series** | HIGH EFFICIENCY ENERGY SAVING

*Improved driver's view*

- > Standard configuration of wide view mast compact structure of mast and tube pulley block.
- > Large arc of overhead guard and angle optimized grid tray enlarge driver's upper view.

*Improved operating comfort*

- > 25mm lowered pedal height, 100% enlarged accelerator panel and 40% enlarged brake pedal improve driver's foot operating comfort.
- > Super low torque steering unit makes steering light and easy.
- > Rear handle with horn button ensures safe and comfortable operation while reverse driving.
- > Mast and rear axle buffering improve driving comfort largely.
- > Ratchet hand brake has different brake force on slope and ground, reducing driver's fatigue.



*Optimized maintainability and safety*

- > Special side plate and top cover structure is easy for assembly and disassembly.
- > Highly-mounted rear axle increasing transversal stability by 2.1%.
- > Two driving modes offer optional choices to different working condition.
- > Automatic deceleration when steering is optional so as to ensure the operation safety.

*High efficiency and energy-saving*

- > The use of electric truck dedicated tire with pattern saves more than 10% of the energy during travelling.
- > LED lamps save 80% of the energy.
- > The professional matching design of the components prolongs the battery working time about 10%.

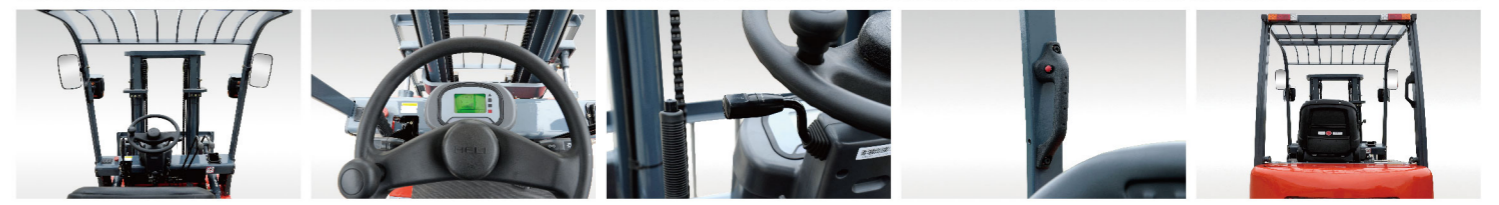

Manufacturer's Data and Design Characteristics

Character	HEU						
Character	CPD10	CPD15	CPD15	CPD18	CPD20	CPD25	
1.01 Manufacturer	HEU						
1.02 Model	CPD10	CPD15	CPD15	CPD18	CPD20	CPD25	
1.03 Configuration number	HA1/HA2	HA1/HA2	HC1/HC2	HC1/HC2	HA1/HA2	HA1/HA2	
1.04 Rated capacity	1000	1500	1500	1750	2000	2500	
1.05 Load center distance	500	500	500	500	500	500	
1.06 Power mode	Battery	Battery	Battery	Battery	Battery	Battery	
1.07 Driving mode	Seated	Seated	Seated	Seated	Seated	Seated	
1.08 Wheel base	L1	1280	1390	1390	1535	1535	
Type							
2.01 Tyre type	Pneumatic	Pneumatic	Pneumatic	Pneumatic	Pneumatic	Pneumatic	
2.02 Wheel number(front/rear)	2/2	2/2	2/2	2/2	2/2	2/2	
2.03 Front wheel base	W3	890	890	890	960	960	
2.04 Rear wheel base	W2	920	920	920	950	950	
2.05 Tyre (front)	6.50-10-10PR	6.50-10-10PR	6.50-10-10PR	6.50-10-10PR	7.00-12-12PR	7.00-12-12PR	
2.06 Tyre(rear)	16 x 6-8-10PR	16 x 6-8-10PR	16 x 6-8-10PR	16 x 6-8-10PR	18 x 7-8-14PR	18 x 7-8-14PR	
Size							
3.01 Front overhang	L2	410	410	410	465	465	
3.02 Mast tilt angle, front/rear	a/β	6/12	6/12	6/12	6/12	6/12	
3.03 Height with mast retraction	H1	1995	1995	1995	2000	2000	
3.04 Free lifting height	H3	150	150	150	170	170	
3.05 Max. Lifting height	H	3000	3000	3000	3000	3000	
3.06 Max. Height under working condition	H2	4040	4040	4040	4042	4042	
3.07 Overhead guard height	H4	2130	2130	2130	2155	2155	
3.08 Fork size(thickness*width*length)	T×W×L	32 × 100 × 770	35 × 100 × 920	35 × 100 × 920	35 × 100 × 920	40 × 122 × 1070	
3.09 Fork arm carrier, din standard	2A	2A	2A	2A	2A	2A	
3.10 Truck body length (fork excluded)	L'	2065	2065	2175	2400	2400	
3.11 Truck body width	W1	1070	1070	1070	1150	1150	
3.12 Turning radius	r	1770	1770	1880	2065	2065	
3.13 Clearance between mast and ground	H5	110	110	110	115	115	
3.14 Clearance between wheel base center and ground(loaded)	H6	120	120	120	135	135	
3.15 Right angle stacking aisle width (pallet1000x1000mm, clearance 200mm)	Ast	3380	3380	3490	3730	3730	
3.16 Right angle stacking aisle width (pallet1200x1200mm, clearance 200mm)	Ast	3580	3580	3690	3930	3930	
3.17 Lateral fork adjustment(outside of forks)max./min.	960/200	960/200	960/200	960/200	1030/244	1030/244	
Performance							
4.01 Travelling speed: loaded/unloaded	km/h	14/15	14/15	14/15	14/15	14/15	
4.02 Lifting speed: loaded/unloaded	m/s	0.290/0.45	0.270/0.45	0.270/0.45	0.280/0.53	0.280/0.49	
4.03 Lowering speed	m/s	0.45	0.45	0.45	0.45	0.45	
4.04 Gradeability (loaded)	%	18	17	17	15	15	
4.05 Max. Traction force (loaded)	N	7800	8600	8800	9500	12900	
4.06 Acceleration time (10m) loaded/unloaded	s	5.2/5.0	5.4/5.2	5.4/5.2	5.6/5.4	6.2/6.0	
Weight							
5.01 Total weight (with /without battery)	kg	2880/2030	2950/2300	2980/2220	3150/2390	4080/3090	4230/3230
5.02 Axle load: unloaded, front/rear	kg	1215/1465	1330/1620	1445/1535	1450/1700	1960/2120	1950/2280
5.03 Axle load: loaded, front/rear	kg	3080/600	3900/550	3930/550	4400/500	5220/860	6020/710
Battery							
6.01 Battery voltage/capacity k5	V/Ah	48/400	48/400	48/480	48/480	48/600	48/600
6.02 Battery weight	kg	650(600-1000)	650(600-1000)	760(700-1000)	760(700-1000)	1000(950-1300)	1000(950-1300)
6.03 Battery, din standard	43531A	43531A	43531A	43531A	43531A	43531A	
Motor and controller							
7.01 Drive motor power-60 minutes	kW	8.0	8.0	8.0	8.0	11.1	
7.02 Lifting motor power-15 minutes	kW	7.5	7.5	7.5	8.6	10.5	
7.03 Drive motor controlling mode	MOSFET/AC	MOSFET/AC	MOSFET/AC	MOSFET/AC	MOSFET/AC	MOSFET/AC	
7.04 Lifting motor controlling mode	MOSFET/DC	MOSFET/DC	MOSFET/DC	MOSFET/DC	MOSFET/DC	MOSFET/DC	
7.05 Service brake/parking brake	Hydraulic/Mechanical	Hydraulic/Mechanical	Hydraulic/Mechanical	Hydraulic/Mechanical	Hydraulic/Mechanical	Hydraulic/Mechanical	
7.06 Hydraulic system working pressure	Mpa	14.5	14.5	14.5	17.5	17.5	

NOTE: \*Detailed information about battery, please contact our salesmen or engineers.

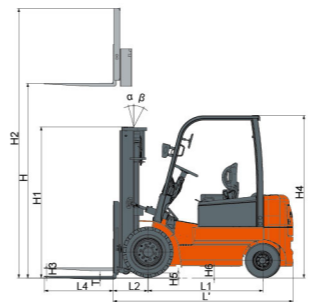

Ast: Right angle stacking aisle width  
a: Clearance  
b: Load Length

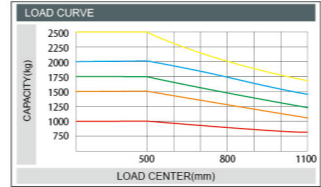
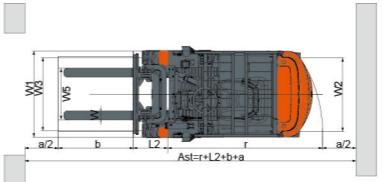

NOTE: The vertical axis stands for load capacity and the horizontal axis stands for load center which is calculated from the front surface of the forks to the gravity of the standard load, the standard load means a cubic with 1000mm edge length. When mast is tilted forward, using non-standard forks or loading large goods, the load capacity will be reduced. The load capacity of standard mast at different load center can be known from this load chart.

WIDE VIEW MAST															
Mast model	Max lifting height (mm)	Load capacity (load center 500mm)(kg)					Mast overall height (fork to the ground)(mm)					Mast tilt angle (°)α/β			
		1t	1.5t	1.8t	2t	2.5t	1-1.8t	2-2.5t	1t	1.5(A)	1.5(C)				
M200	2000	1000	1500	1750	2000	2500	1495	1500	2615	2885	2915	3085	3990	4140	6/12
M250	2500	1000	1500	1750	2000	2500	1745	1750	2645	2915	2945	3115	4035	4185	6/12
M300	3000	1000	1500	1750	2000	2500	1995	2000	2680	2950	2980	3250	4080	4230	6/12
M330	3300	1000	1500	1750	2000	2500	2145	2150	2710	2970	3000	3170	4105	4255	6/12
M350	3500	1000	1500	1750	2000	2500	2245	2250	2740	2980	3100	3180	4125	4275	6/12
M370	3700	1000	1500	1750	2000	2500	2345	2350	2725	2995	3025	3195	4140	4290	6/6
M400	4000	1000	1500	1750	2000	2450	2545	2550	2775	3045	3075	3245	4200	4350	6/6
M425	4250	1000	1400	1650	1850	2250	2670	2675	2790	3060	3090	3260	4225	4375	6/6
M450	4500	950	1350	1550	1800	2150	2795	2800	2805	3075	3105	3275	4250	4400	6/6
M500	5000	930	1300	1500	1750	2000	3045	3050	2840	3110	3140	3310	4295	4445	6/6
M550	5500	900	1250	1450	1700	1950	3345	3350	2900	3170	3200	3370	4370	4520	6/6
M600	6000	850	1200	1400	1650	1900	3595	3600	2930	3200	3230	3400	4420	4570	6/6

NOTE: (1) \* refers to rated capacity with double tires.

WIDE VIEW FULL FREE 2-STAGE MAST																	
Mast model	Max lifting height (mm)	Load capacity (load center 500mm)(kg)					Mast overall height (fork to the ground)(mm)					Service weight(kg)			Mast tilt angle (°)α/β		
		1t	1.5t	1.8t	2t	2.5t	1-1.8t	2-2.5t	1t	1.5(A)	1.5(C)	1.8t	2t	2.5t			
ZM200	2000	1000	1500	1750	2000	2500	1495	1500	485	495	2660	2930	2960	3130	4000	4150	6/12
ZM250	2500	1000	1500	1750	2000	2500	1745	1750	735	745	2690	2960	2990	3160	4045	4195	6/12
ZM300	3000	1000	1500	1750	2000	2500	1995	2000	985	840	2725	2995	3025	3295	4095	4245	6/12
ZM330	3300	1000	1500	1750	2000	2500	2145	2150	1135	990	2750	3020	3050	3320	4115	4265	6/12
ZM350	3500	1000	1500	1750	2000	2500	2245	2250	1285	1090	2760	3030	3060	3330	4145	4295	6/12
ZM370	3700	1000	1500	1750	2000	2450	2345	2350	1335	1205	2775	3045	3075	3345	4160	4310	6/6
ZM400	4000	1000	1500	1750	2000	2400	2545	2550	1535	1390	2825	3095	3125	3395	4250	4375	6/6
ZM425	4250	1000	1400	1650	1850	2250	2670	2675	1660	1515	2840	3110	3140	3310	4250	4400	6/6
ZM450	4500	950	1350	1550	1800	2150	2795	2800	1785	1640	2860	3130	3160	3330	4275	4425	6/6
ZM500	5000	930	1300	1500	1750	2000	3045	3050	2035	1910	2895	3165	3195	3365	4320	4470	6/6
ZM550	5500	900	1250	1450	1700	1950	3345	3350	2335	2190	2955	3225	3255	3425	4405	4555	6/6
ZM600	6000	850	1200	1400	1650	1900	3595	3600	2585	2440	2990	3260	3290	3460	4455	4605	6/6

NOTE: (1) \* refers to rated capacity with double tires.  
(2) 1-1.8t: free lifted height 365mm increased without backrest.  
(3) 2-2.5t: free lifted height 290mm increased without backrest.

WIDE VIEW FULL FREE 3-STAGE MAST																	
Mast model	Max lifting height (mm)	Load capacity (load center 500mm)(kg)					Mast overall height (fork to the ground)(mm)					Service weight(kg)			Mast tilt angle (°)α/β		
		1t	1.5t	1.8t	2t	2.5t	1-1.8t	2-2.5t	1t	1.5(A)	1.5(C)	1.8t	2t	2.5t			
ZSM260	3600	1000	1450	1750	2000	2400	1795	1795	695	795	2775	3045	3075	3245	4205	4355	6/6
ZSM400	4000	1000	1400	1600	1900	2300	1925	1920	910	920	2800	3070	3100	3270	4240	4390	6/6
ZSM435	4350	950	1300	1500	1850	2200	2040	2045	1025	1045	2820	3090	3120	3390	4275	4425	6/6
ZSM450	4500	950	1300	1500	1750	2100	2090	2095	1075	1095	2830	3100	3130	3300	4285	4435	6/6
ZSM470	4700	930	1280	1450	1720	2000	2160	2160	1075	1160	2850	3120	3150	3320	4305	4455	6/6
ZSM480	4800	920	1250	1400	1700	1950	2190	2195	1145	1195	2860	3130					