

CHL



1-1.8 ton
ENGINE POWERED
FORKLIFT

CHL



1-1.8ton
ENGINE POWERED
FORKLIFT

STANDARD EQUIPMENT

Hour meter
Horn
Oil pressure alarm
Throttle control valve
Power steering
Rubber pedal pad
Backrest
Backview mirror
Front combined lights
Transmission oil filter
Engine flameout device
Parking brake cable
Water temperature meter
Attached tools
Rear combined lights
Reversing buzzer
Self-locking tilt valve
Tilt adjustable steering column

Overhead guard
Standard forks
Central Control Box
Hydraulic circuit oil filter
Radiator tank
Speed-limiting valve
Oil meter
Battery-charge indicator
Wide-view mast
Intake device
Durable tire
Operating handles
Traction pin
Standard seat
Hydraulic oil gauge
Overhead guard raincoat
Torque converter oil gauge
Combined display

OPTIONS

Cab
Rotating warning light
Vertical exhaust
Double air filter
Suspension seat
Extended fork sleeve
Heater
Solid tire
Widening fork carriage
Windglass
Purifying muffler
Fire muffler
Fire extinguisher
Rear lights
Air conditioning (some models)
Electro-hydraulic switch
OPS driving control
Torque converter oil temperature meter

Tilt cylinder sleeve
Steering cylinder sleeve
User-specified color
Optional attachments
Steel protective fences
Dual tire sand protective devices
LPG with the flip seat
LPG single and dual-fuel system
Power brake
Side shifter



Jl. Inspeksi Kalimalang KM. 22 Blok A Gudang A-01,
Cibuntu, Bekasi - 17530

Telp : (021) 8953 5873
Mobile : +62 819 555 5969
Email : thubastunggalperkasa@gmail.com
Website : www.thubastunggalperkasa.co.id

*Details of specifications and equipment are based on information available at the time of printing and may change without notice.

© 2013 heli copyright

Catalog No.2013.1.0 HELI Print



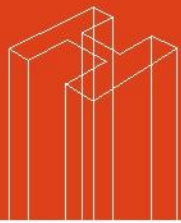

ENGINE POWERED
FORKLIFT

1-1.8 ton

CHL

Reliable forklift

A reliable Drive system



As the most reliable transmission system produced by HELI, it has been validated by over twenty years' experience in World market. Meanwhile, various ancillary devices of the power system ensure the reliability effectively.

- ✓ Durable transmission
- ✓ Equipped with the intake system & intake silencer
- ✓ Optional air filter pressure alarm device
- ✓ Automatic engine preheating system
- ✓ Cydome Air Filter
- ✓ Lost foam casting
- ✓ Various high-power engines are available for customers' optional choices, and the emission meets the latest European & American environmental regulation.

A reliable mast



The high internal-qualified mast confirmedly ensures the safety of the operator, truck and cargo. Standard configuration of the wide-view mast enlarges operators' view effectively, and ensures loading /unloading operations more reliable.

- ✓ Using the best German steel material for triplex mast (option only for triplex mast)
- ✓ The frame of mast has more strength basing on the enlarged channel interface.
- ✓ Clear visibility for standard wide-view mast
- ✓ The channel with own patented technology has the first-rate quality.

Comfortable operation space

Large operation space with ergonomic-design and configuration ensure the operation more comfortable & convenient, and effectively enhance the efficiency & safety of operation.

- ✓ Filled with noise-reducing and buffer rubber material between bonnet and frameworks
- ✓ Newly patented insulation materials of Bonnet
- ✓ Well-designed non-slip mat
- ✓ Special display with easily reading
- ✓ Standard files packet
- ✓ Exhaust system is flexibly connected with the frame.

A reliable hydraulic system

HELI has the most professional R&D base of cylinders, where we take advantage of the advanced manufacturing technologies and detecting means to ensure the reliability of all cylinders of the hydraulic system.

- ✓ Standard tilt cylinder by HELI
- ✓ Standard lift cylinder by HELI
- ✓ Standard steering cylinder by HELI
- ✓ Self-locking tilt cylinder
- ✓ Standard hydraulic circuit filter
- ✓ Speed buffer device on lifting system



A reliable steering system

The steering system with new technologies not only provides a smoother swerve and faster positioning & steering, but also effectively ensures operators' safety.



- ✓ Wearable tire
- ✓ Smaller turning radius
- ✓ Full hydraulic powersteering



ENGINE POWERED
FORKLIFT

1-1.8 ton



Manufacturers Data and Design Characteristics														
Characteristics														
1	Manufacturer	ANHUI HEUI CO., LTD.												
2	Model	CPC10	CPCD10	CPC15	CPCD15	CPC18	CPCD18	CPQ10	CPQD10	CPQ15	CPQD15	CPQ18	CPQD18	
3	Power unit	Diesel						Gasoline						
4	Rated Capacity	kg	1000	1500	1750	1000	1500	1750						
5	Load Center	mm	500											
6	Operation	Driver seated												
Dimensions														
7	Overall max lifting height (with backrest)	h4	mm	4030	4030	4030	4030	4030	4030	4030	4030	4030	4030	
8	Max Lifting height	h3	mm	3000										
9	Height mast retracted(upright)	h1	mm	1995	1995	1995	1995	1995	1995	1995	1995	1995	1995	
10	Free lift height	h2	mm	152	155	155	152	155	155	152	155	155	152	
11	Backrest height(from upper face of forks)	h8	mm	1008	1005	1005	1008	1005	1008	1005	1008	1005	1008	
12	Overhead Guard clearance(from face of seat)	h7	mm	1025										
13	Overall height(overhead guard)	h6	mm	2070	2070	2070	2070	2070	2070	2070	2070	2070	2070	
14	Overall length(with forks)	L1	mm	2941	3165	3213	2941	3165	3213	2941	3165	3213	2941	
15	Overall length(without forks)	L2	mm	2171	2245	2293	2171	2245	2293	2171	2245	2293	2171	
16	Front overhang	X	mm	418	421	421	418	421	421	418	421	421	418	
17	Rear overhang	L4	mm	350	420	465	350	420	465	350	420	465	350	
18	Wheel base	L5	mm	1400	1400	1400	1400	1400	1400	1400	1400	1400	1400	
19	Coupler height	h5	mm	250	250	250	250	250	250	250	250	250	250	
20	Min.ground clearance under mast	m1	mm	110	110	110	110	110	110	110	110	110	110	
21	Overall width	B	mm	1070	1070	1070	1070	1070	1070	1070	1070	1070	1070	
22	Lateral fork adjustment outside of fork(Max./Min.)	S	mm	950/200										
23	Tread(front)	R	mm	890	890	920	890	890	920	890	890	920	890	
24	Tread(rear)	P	mm	920	920	920	920	920	920	920	920	920	920	
25	Outside turning radius	Wa	mm	1880	1955	1985	1880	1955	1985	1880	1955	1985	1880	
26	Inside turning radius	V	mm	110	110	95	110	110	95	110	110	95	110	
27	Min.intersecting aisle	Ra	mm	1977	2052	2093	1977	2052	2093	1977	2052	2093	1977	
28	Tilting angles(forward/backward)	α/β		6° /12°										
29	Fork dimensions(axbxc)	mm		770 × 100 × 32	920 × 100 × 35	920 × 100 × 35	770 × 100 × 32	920 × 100 × 35	920 × 100 × 35	770 × 100 × 32	920 × 100 × 35	920 × 100 × 35	920 × 100 × 35	
Performance														
30	Max. Traveling speeds(With/Without load)	km/h	13.5/14.5											
31	Lifting Speeds(With/Without load)	mm/s	590/650											
32	Lowering Speeds(With/Without load)	mm/s	450/550											
33	Max. Draw-bar pull (With/Without load)	kN	12.3/7	18/7	12.3/7	18/7	12.3/7	18/7	9.3/6.9	14.2/6.9	9.3/6.9	14.2/6.9	9.3/6.9	14.2/6.9
34	Max. Negotiable Gradient(With/Without load)	%	≥ 20						30/22	37/22	23/18	27/18	20/17	24/17
Weights														
35	Service Mass	kg	2220	2660	2890	2220	2660	2890	2220	2660	2890	2220	2660	2890
36	Load Wheel with load(Front/Rear)	kg	2830/390	3640/520	4040/600	2830/390	3640/520	4040/600	2830/390	3640/520	4040/600	2830/390	3640/520	4040/600
37	Load Wheel without load(Front/Rear)	kg	1220/1000	1170/1490	1140/1750	1220/1000	1170/1490	1140/1750	1220/1000	1170/1490	1140/1750	1220/1000	1170/1490	1140/1750
Tyres														
38	Wheels number front/rear(x=driven)		2X/2											
39	Tyre Type		Pneumatic											
40	Tyre size(front)		6.50-10-10PR											
41	Tyre size(rear)		5.00-8-8PR											
42	Service Brake		Hydraulic-Foot Pedal											
43	Parking Brake		Mechanical-Hand Lever											
Drive														
44	Battery (Voltage/Capacity)	VAh	12/80						12/60					
45	Internal Combustion Engine Model		ISUZU C240PKJ						NISSAN K15					
46	Internal Combustion Engine Rated Output	kW/rpm	35.4/2500						23.6/2400					
47	Internal Combustion Engine Rated Torque	Nm/rpm	139.9/1800						103/1600					
48	Internal Combustion Engine Number of Cylinder		4-86 × 102						4-75.5 × 83					
49	Internal Combustion Engine Displacement	L	2.369						1.468					
50	Internal Combustion Engine Fuel Tank Capacity	L	38						38					
51	Transmission Number of Speed Fwd/Bwd type		1-1 Power Shift T/M, 2-2 Manual Shift T/M						1-1 Power Shift T/M, 2-2 Manual Shift T/M					

Engine Model and Main Specification for Option

Engine Model	Rated Power / Rotating Speed [kW/rpm]	Rated Torque / Rotating Speed [Nm/rpm]	Engine Capacity [L]	Number of cylinders	Remark
Kubota V2403	35.4/2400	161.3/1600	2.434	4	For 1-1.8t
JIAN GUANG HJ49B	33/2300	153/1800	2.771	4	For 1-1.8t
XINCHANG NC485BPG	30/2600	131/1700~1900	2.27	4	For 1-1.8t

Reliable special designed instrument

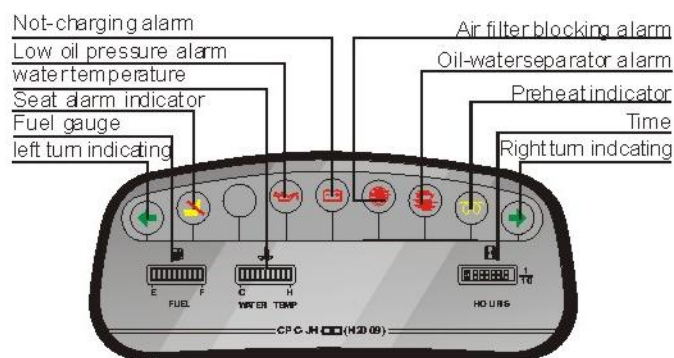

Standard

The reliable special instrument gives a complete display of the vital information, like operation status, fault detection, etc. It ensures the operator predominate the vehicle status more intuitive and convenient.

- ✓ Stepping motor core
- ✓ Electrical safety standard meets CE requirements

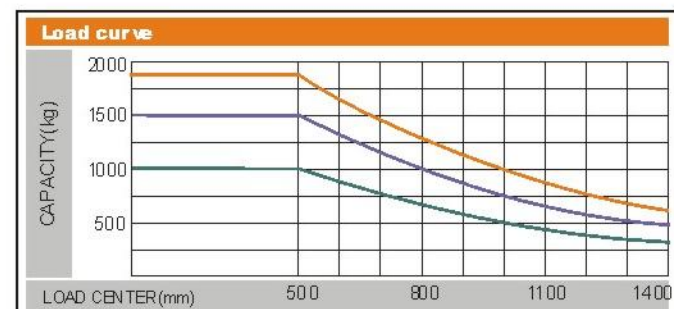
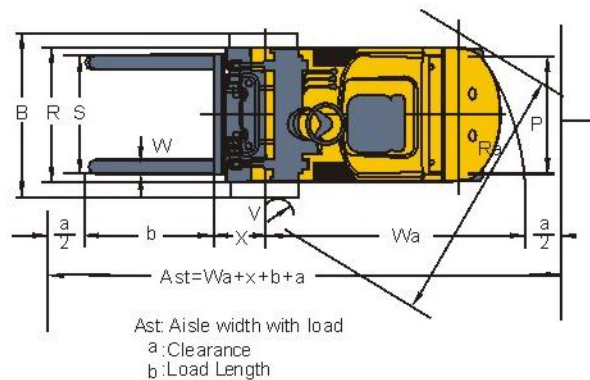
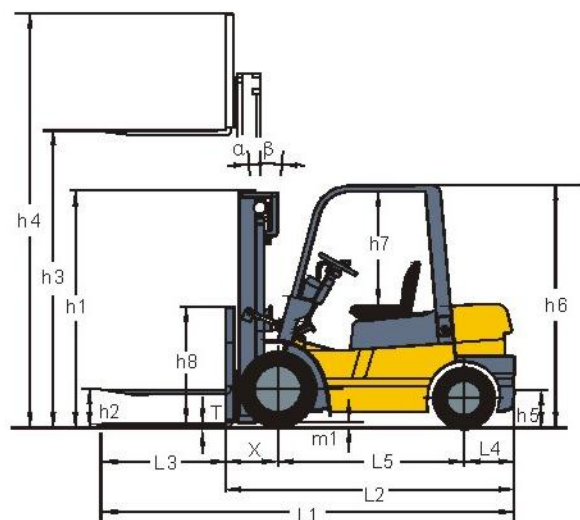

CPQ18/CPQD18 CPQ15/CPQD15 CPQ10/CPQD10
CPQ18/CPQD18 CPQ15/CPQD15 CPQ10/CPQD10

Note:

Capacities shown are computed with upright in vertical position, based on a 1000mm cube load configuration with the center of gravity at the true center of the cube, and standard forks. Truck capacities with upright in forward tilt position will be less. Longforks, an unusually wide or loads may also reduce capacity.

1-1.8t WIDE VIEW MAST

Mast model	Max. fork height (mm)	Capacity at 500mm; Load center (kg)			Overall Mast Height (mm)	Tilting Angle	Service Weight (kg)		
		CPQ10/CPQD10 CPC10/CPCD10	CPQ15/CPQD15 CPC15/CPCD15	CPQ18/CPQD18 CPC18/CPCD18			CPQ10/CPQD10 CPC10/CPCD10	CPQ15/CPQD15 CPC15/CPCD15	CPQ18/CPQD18 CPC18/CPCD18
M200	2000	1000	1500	1750	1495	6-12	2120	2530	2750
M250	2500	1000	1500	1750	1745	6-12	2145	2555	2785
M300	3000	1000	1500	1750	1995	6-12	2220	2600	2890
M330	3300	1000	1500	1750	2145	6-12	2195	2605	2835
M350	3500	1000	1500	1750	2245	6-12	2210	2620	2850
M370	3700	1000	1500	1750	2345	6-6 6-12	2230	2640	2870
M400	4000	1000	1500	1700 *1750	2545	6-6 6-12	2270	2680	2910
M425	4250	950	*1500 *1600	*1750 *1750	2670	6-6 6-12	2285	2695	2925
M450	4500	950	*1300 *1400	*1550 *1700	2795	6-6 6-12	2300	2710	2940
M500	5000	900 *950	1100 *1250	1100 *1600	3045	6-6 6-6	2335	2745	2975
M550	5500	*900	*1150	*1500	3345	*3-6	2500	2910	3140
M600	6000	*850	*1050	*1400	3595	*3-6	2530	2940	3170

- NOTE: (1) For gas, diesel model: +60kg dual wheels weight +110kg.
(2) *(front wheel) is dual wheels load capacity.
(3) Rate d capacity with (*): shows capacity with front dual tires.
(4) Max. lifting height without lift-bracket: 470mm.

1-1.8t WIDE VIEW FULL FREE 2-STAGE MAST

Mast model	Max. fork height (mm)	Capacity at 500mm; Load center (kg)			Overall Mast Height (mm) At Lowered	Free Lift (with Backrest)	Tilting Angle	Service Weight (kg)		
		CPQ10/CPQD10 CPC10/CPCD10	CPQ15/CPQD15 CPC15/CPCD15	CPQ18/CPQD18 CPC18/CPCD18				CPQ10/CPQD10 CPC10/CPCD10	CPQ15/CPQD15 CPC15/CPCD15	CPQ18/CPQD18 CPC18/CPCD18
ZM200	2000	1000	1500	1750	1535	520	6-12	2135	2555	2795
ZM250	2500	1000	1500	1750	1745	735	6-12	2195	2615	2855
ZM300	3000	1000	1500	1750	1995	985	6-12	2230	2650	2890
ZM330	3300	1000	1500	1750	2145	1135	6-12	2250	2670	2910
ZM350	3500	1000	1500	1750	2245	1235	6-12	2265	2685	2925
ZM370	3700	1000	1500	1750	2370	1360	6-6 6-12	2280	2700	2940
ZM400	4000	1000	1500	1700 *1750	2545	1535	6-6 6-12	2330	2750	2990
ZM425	4250	950	*1500 *1600	*1750 *1750	2670	1660	6-6 6-12	2350	2770	3010
ZM450	4500	950	*1300 *1400	*1550 *1700	2795	1785	6-6 6-12	2365	2785	3025
ZM500	5000	900 *950	1100 *1250	1100 *1600	3045	2035	6-6 6-6	2400	2820	3060
ZM550	5500	*900	*1150	*1500	3345	2335	*3-6	2575	2995	3235
ZM600	6000	*850	*1050	*1400	3595	2585	*3-6	2610	3030	3270

- NOTE: (1) Dual wheels weight +110kg.
(2) *(front wheel) is dual wheels load capacity.
(3) Max. lifting height without bracket: 470mm.
(4) Free lifting height without bracket: 470mm.
(5) Rate d capacity with (*): shows capacity with front dual tires.

1-1.8t WIDE VIEW FULL FREE 3-STAGE MAST

Mast model	Max. fork height (mm)	Capacity at 500mm; Load center (kg)			Overall Mast Height (mm) At Lowered	Free Lift (with Backrest)	Tilting Angle	Service Weight (kg)		
		CPQ10/CPQD10 CPC10/CPCD10	CPQ15/CPQD15 CPC15/CPCD15	CPQ18/CPQD18 CPC18/CPCD18				CPQ10/CPQD10 CPC10/CPCD10	CPQ15/CPQD15 CPC15/CPCD15	CPQ18/CPQD18 CPC18/CPCD18
ZSM200	2000	1000	1450	1750	1790	780	6-6 6-6	2275	2695	2935
ZSM250	2500	1000	1400	1600	1915	910	6-6 6-6	2300	2720	2960
ZSM265	2650	900 *950	1350 *1400	1550 *1700	2040	1030	6-6 6-6	2325	2745	2985
ZSM280	2800	900 *950	1300 *1350	1500 *1650	2090	1080	6-6 6-6	2355	2750	2995
ZSM290	2900	900 *950	1300 *1350	1450 *1600	2160	1150	6-6 6-6	2365	2760	3005
ZSM300	3000	900 *950	1300 *1350	1400 *1550	2190	1180	6-6 6-6	2375	2775	3010
ZSM330	3300	900 *950	1100 *1250	1100 *1600	2490	1280	6-6 6-6	2400	2780	3035
ZSM340	3400	800 *850	1050 *1100	1050 *1500	2415	1410	3-6 3-6	2420	2815	3055
ZSM350	3500	*900	*1250	*1500	2550	1640	*3-6	2480	2875	3115
ZSM360	3600	*850	*1100	*1400	2800	1890	*3-6	2530	2925	3165
ZSM370	3700	-	-	*800	3025	2015	*3-6	2580	2975	3215

- NOTE: (1) Dual wheels weight +110kg.
(2) *(front wheel) is dual wheels load capacity.
(3) Max. lifting height without bracket: 470mm.
(4) Free lifting height without bracket: 470mm.
(5) Rate d capacity with (*): shows capacity with front dual tires.