

a: 间隙
b: 载荷中心

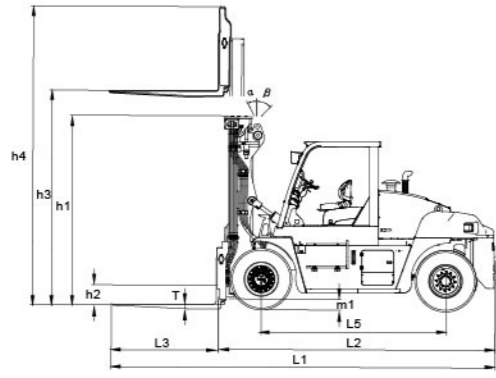
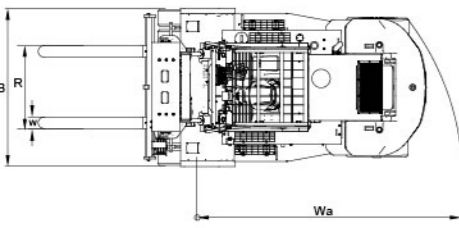

性能参数 Performance specifications					
型号 Model	CPCD140	CPCD150	CPCD160	CPCD180	
单位 Unit	mm				
外形尺寸 Overall dimension	L1全长 (带货叉) Overall length (with forks)	6270			
	B全宽 Overall width	2780			
	h1全高 (门架) Overall height (at mast)	3300			
	h4作业时最大高度 Overall height (at works)	4776			
L5轴距 Wheel base	3250				
h3起升高度 (标准) Lift height (standard)	3000				
m1最小离地间隙 (门架处) Min. underclearance	345				
货叉 Fork	L3货叉长度 Length	1370			
	W货叉宽度 Width	200			
	T货叉厚度 Thickness	85			
	R货叉调节范围 Adjustable range	500-2370			
Wa最小转弯半径 (外部) Min. turning radius (external)	4500				
α/β 门架倾角 Mast tilt angle (fwd/bwd)	6° /12°				

宽视野基本型门架 Wide view basic type mast								
门架类型 Mast type	最大起升高度 Max. lifting height (mm)	承载能力(载荷中心600mm) Loading capacity (load center 600mm) (kg)				门架落地全高 Free lift height (mm)	门架倾角(前/后) Mast tilt angle (Fwd/Bwd)	备注 Note
		CPCD140	CPCD150	CPCD160	CPCD180			
M300	3000	14000	15000	16000	18000	3300	6° /12°	标准型 Standard type
M350	3500	14000	15000	16000	18000	3550	6° /12°	
M400	4000	14000	15000	16000	18000	3800	6° /12°	
M450	4500	14000	15000	16000	18000	4050	6° /12°	
M500	5000	14000	15000	16000	18000	4300	6° /6°	
M550	5500	13000	14000	15000	17000	4550	3° /6°	
M600	6000	12000	13000	14000	16000	4800	3° /6°	
M650	6500	11000	12000	13000	15000	5050	3° /6°	

- 合力产品不断更新和改进中，合力保留在没有事先告知用户的情况下，更改整体参数及设计的权利。Our products are constantly updated and improved. Parameters and design are subject to change without prior notice.
- 文中插图不一定是该机型的标准款，插图中产品配置和外观颜色与实际机型存在差异，以实物为准。The configuration and color of the products in figures may be different from the actual delivered model. Please in kind prevails.

HELI
中国合力 提升未来



Jl. Inspeksi Kalimalang KM. 22 Blok A Gudang A-01, Cibuntu, Bekasi - 17530
Telp : (021) 8953 5873
Mobile : +62 819 555 5969
Email : thubastunggalperkasa@gmail.com
Website : www.thubastunggalperkasa.co.id

Contact sales :



HELI
中国合力 提升未来



G系列轻型
14-18t内燃平衡重式叉车
G Series Light Type 14-18t
Internal Combustion Counterbalanced Forklift Truck



G SERIE FORKLIFT
CPCD 140-180

性能参数 Performance specifications					
型号 Model	单位 Unit	CPCD140-CU-06IIG	CPCD150-CU-06IIG	CPCD160-CU-06IIG	CPCD180-CU-06IIG
额定起重量 Rated capacity	kg	14000	15000	16000	18000
载荷中心距 Load center	mm	600			
动力形式 Power type		柴油 Diesel engine			
起升速度 (空载/满载) Lifting speed (unloaded/loaded)	mm/s	350/300			
下降速度 (空载/满载) Descending speed (unloaded/loaded)	mm/s	380/310			
最大行驶速度 (满/空载) Max. Travelling speed (loaded/unloaded)	km/h	27/30			
最大爬坡能力 (满/空载) Max. Gradeability (loaded/unloaded)	%	20%			
轮胎 Tire	类型 (前/后) Type (front/rear)	充气胎4/2 Pneumatic tire			
	规格 Size	12.00-24-20PR			
蓄电池电压/容量 Battery voltage/capacity	V/Ah	24/120			
行车制动器 Service brake		气顶油-踏板式 Gas cap oil- pedal type			
停车制动器 Parking brake		湿式多片式 Wet-type multiple disc brake			
发动机 Engine	发动机生产厂型号 Manufacture Model	东风康明斯 Dongfeng Cummins 6BTA5.9-C170			
	额定功率/转速 Rated output/ Speed	kW/rpm	127/2200		
	额定扭矩/转速 Rated torque/ Speed	Nm/rpm	750/1400		
	缸数 Cylinder number		6		
排量 Displacement	L	5.9			
变速箱变速档数 (前/后型式) Transmission gear shift (front/rear type)		4/4 液力换向 Hydraulic reversing			

标准配置 Standard Configuration			
宽视野门架 Wide view mast	倒车灯 Back-up lamp	护顶架 Overhead guard	花纹耐用轮胎 Durable tire with decorative pattern
标准货叉 Standard fork	液压调距叉 Hydraulic fork positioner	灭火器 Fire extinguisher	倾斜可调转向管柱 Tilt and adjustable steering column
转向指示灯 Steering indicator	电喇叭 Electric horn	液压油液位计 Hydraulic oil level gauge	牵引销 Traction pin
倒车镜 Back-up mirror	发动机油压报警 Engine oil pressure alarm	四片多路阀 Four-piece control valve	高排气 High exhaust
前组合灯 Front combination lamp	充电指示 Charging indicator	倾斜油路自锁阀 Tilt self-lock valve	进气装置 Air inlet device
后组合灯 Rear combination lamp	发动机水温表 Water temperature meter of engine	起升油路限速阀 Flow regulator of lifting oil circuit	随车工具 Driver's tool
计时表 Stopwatch	空挡指示 Neutral indicator	全液压力转向 Fully-hydraulic powered steering	
旋转警示灯 Rotary warning lamp	电液换向 Electro-hydraulic changing-over	液压回路滤油器 Oil filter of hydraulic oil loop	
倒车蜂鸣器 Reversing buzzer	机械式空滤器堵塞报警 Mechanical type air filter obstruction alarm	标准座椅 Standard seat	

选用装置和附件 Optional Devices and Accessories		
暖风机 Warm air blower	悬浮座椅 Floating seat	串杆 String rod
空调 Air conditioner	ops行走控制系统 ops service control system	液力侧移调距叉 (单叉调距) Hydraulic side shift fork positioner (Pitch adjustment of single fork)
普通实心胎 Common solid tyre	用户指定颜色 User designated color	无痕实心胎 No trace solid tyre
贴片驾驶室 Cab	侧移器 Side shifter	

G SERIE FORKLIFT

CPCD 140-180

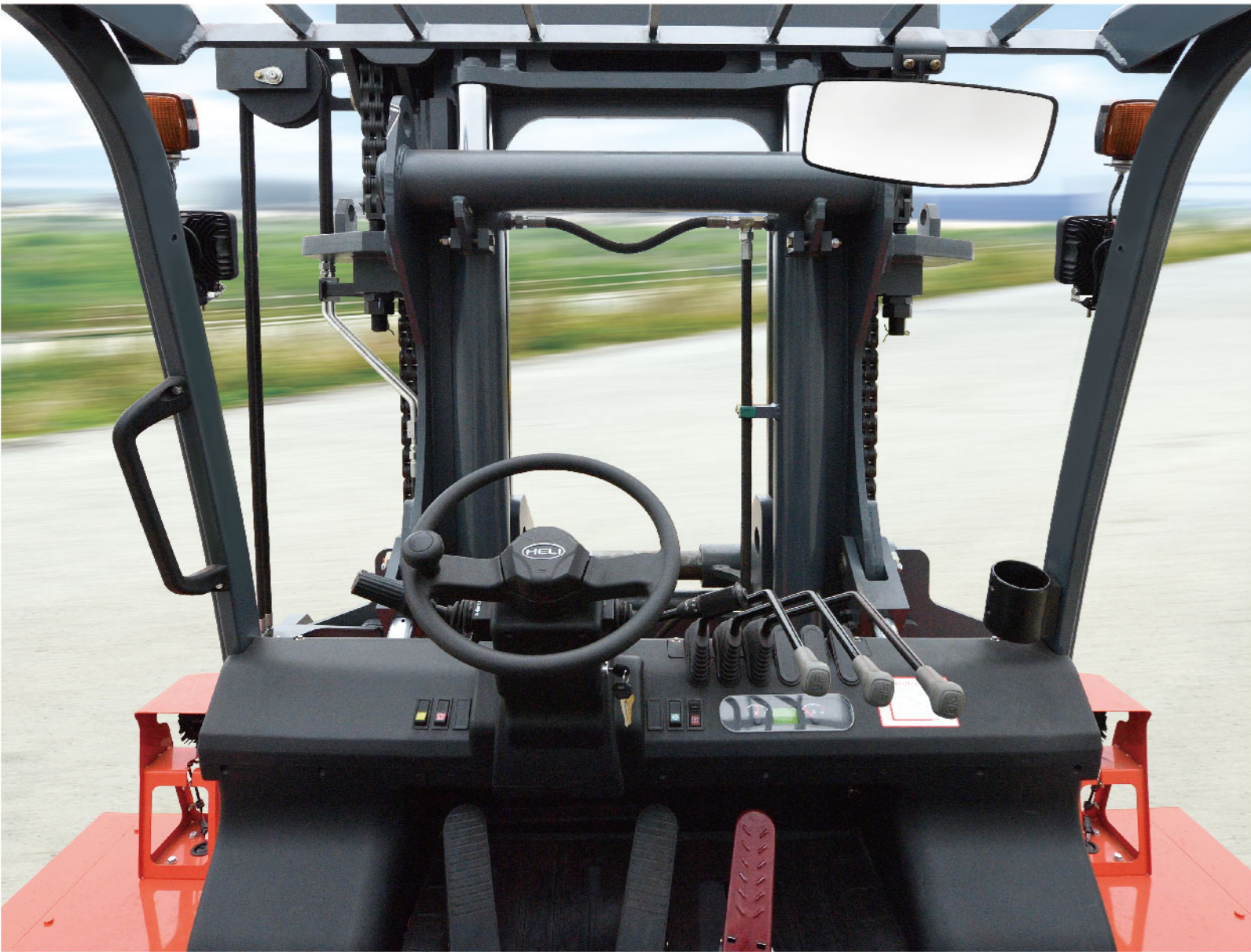

> 发动机系统 Engine System

▶ 东风康明斯6BTAA5.9-C170柴油发动机，国II排放，排量5.9L 油耗低，噪音低，动力输出平稳
参数：127KW/2200rpm 750N.m/1400rpm
燃油系统：采用两节过滤系统，以更好适用低燃油品质的要求。

▶ Dongfeng Cummins 6BTAA5.9-C170 diesel engine meets China II and its displacement is 5.9L. It has low oil consumption, low noise and stable output power.
Parameters: 127kw/2200rpm 750N.m/1400rpm
Fuel system: Two-stage filtering system meets the requirements of low fuel quality better.

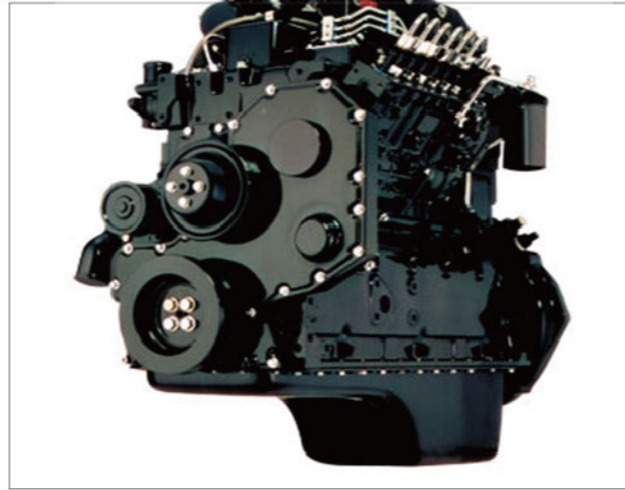

> 变速箱+变矩器 Gearbox & Torque Converter

液力换向变速箱+340高性能变矩器

- ▶ 电液换挡技术
- ▶ 动力匹配更高效
- ▶ 安全可靠噪音低

Hydraulic powered direction changing transmission box+ 340 high performance torque converter

- ▶ Electric-hydraulic gear shifting technology
- ▶ High efficient power matching
- ▶ Safe and reliable; low noise



> 重载驱动桥 Heavy drive axle

▶ 针对叉车特殊工况设计，采用大轮边小主减结构，是驱动桥高可靠性的保证，钳盘制动，拥有良好的使用性能和性价比。

▶ The design is suited to special working conditions of forklift by using big wheel edge and small main reducer, ensuring high reliability of drive axle. Equipped with caliper disc brake, it has good performance and high cost-performance.

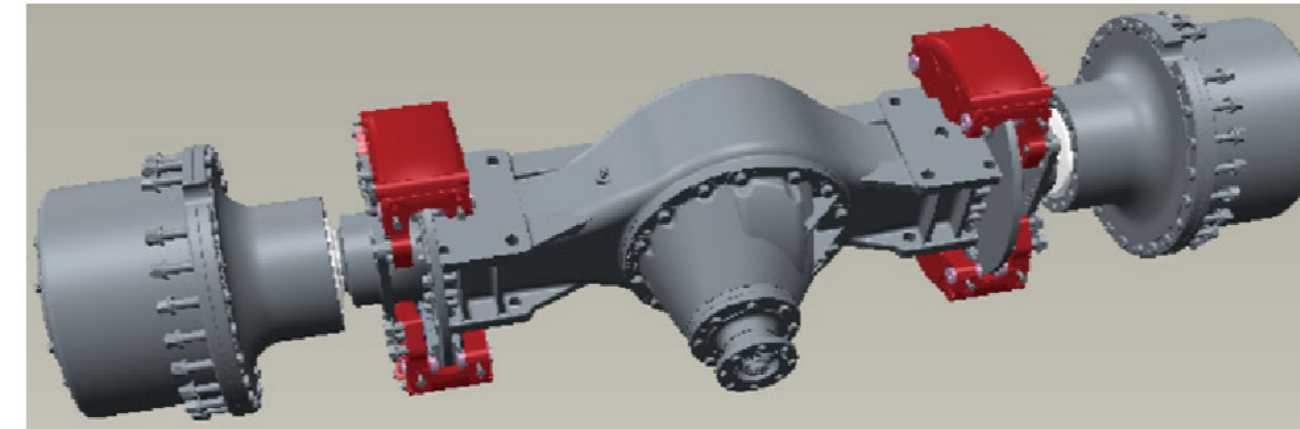

> 制动性能优越 Excellent Braking Performance

- ▶ 整车具有优异、可靠的制动性能，在各种场地条件下，行车制动和停车制动均操作平稳。
- ▶ The whole vehicle has excellent and reliable braking performance and the service brake and parking brake are operated smoothly and stably under various field conditions.

> 液压系统 Hydraulic system

- ▶ 采用意大利沃尔福姆杆操纵式整体多路阀，美国PERMCO高压齿轮泵。
- ▶ Walvoil Lever-operated integrated type control valve from Italy, PERMCO high pressure gear pump.

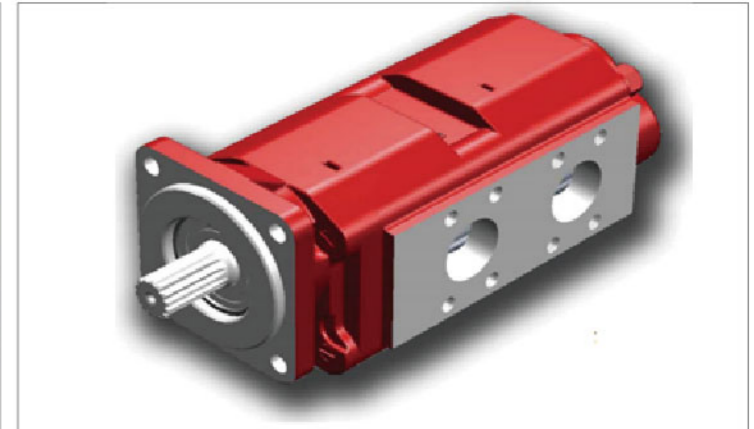
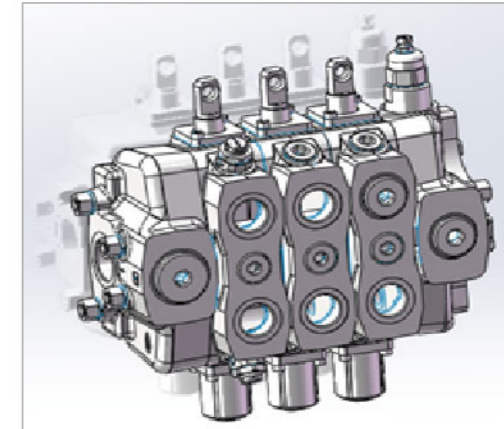

> 宽视野、高强度起重系统 Wide view and High Strength Lifting System

▶ 拥有自主知识产权的宽视野门架与液压调距叉，为操作者提供宽敞的前方视野，有利于工作安全性的改善与工作效率的提高。

▶ Excellent front view which is benefit for the work safety improvement and working efficiency is provide with wide view mast which has proprietary intellectual property and hydraulic fork positioned.

