



主要技术参数 Main technical parameter

型号		Model		CPCD250EC7-VDG	CPCD250EC8-VDG
性能与外形参数 Performance and outline parameters	最大起重量	Rated capacity	Q	kg	见负荷图See load diagram
	载荷中心	Loading center	C	mm	1200
	最大堆高层数	Max. handling layers			7(8'6") 8(8'6")
	可起吊集装箱长度	Length of container lifted		ft	20/ 40
	最大转锁高度	Max. Rotary lock height	H2	mm	18865 21365
	最小转锁高度	Min. rotary lock height	H8	mm	2365
	门架提升高度	Mast lifting height	H4	mm	16500 19000
	门架倾角(前/后)	Mast tilt angle (front/rear)		deg	3/3
	吊具侧移量	Lateral displacement of spreader		mm	± 500
	各档行驶速度	Stall speed		km/h	8/15/29 8/15/29
	最大起升速度(满载/空载)	Max. lifting speed (loaded/unloaded)		mm/s	590/600
	最大下降速度(满载/空载)	Max. descending speed (loaded/unloaded)		mm/s	520/500
	牵引力 满载	Drawbar pull (loaded)		kN	155
	爬坡度 满载	Gradeability (loaded)		%	20
	轴距	Wheel base	L 3	mm	4250
	轮距 前/后	Tread (front/rear)	S1/S2	mm	3290/2395
	长(带属具/不带属具)	Length(with attachment/without attachment)	L	mm	6440/5980 6440/5980
	宽	Width	B		4150
高(门架缩回)	Height (mast retraction)	H3	mm	10370 11620	
驾驶室高	Cab height	H6	mm	5150	
座椅离地高	Height of seat to the ground	H7	mm	4120	
最小转弯半径	Min. turning radius		mm	5918	
直角通道宽度 吊具伸出/缩回	Width of intersecting aisle (spreader extension/ retraction)	A1/A2	mm	14590/10350	
发动机 Engine	柴油发动机 Diesel engine	制造商/型号	Manufacturer/Model		Volvo
		额定功率/额定转速	Rated output/Speed	kW/rpm	174/2300
		最大扭矩/转速	Max. Torque/Speed	Nm/rpm	854/1400
		全负荷最低燃油消耗率	Min. fuel consumption	g/kWh	205
变速箱 Gearbox (变矩器) Torque converter		排量	Displacement	L	7.15
		制造商/型号	Manufacturer/Model		DANA
		变速档数(前进/后退)	Shift gears (forward/backward)		3/3
轮胎 Tire		换档型式	Shift type		自动Automatic
		前轮规格	Front wheel size		14.00-24-24PR
		后轮规格	Rear wheel size		14.00-24-24PR
		气压(前轮/后轮)	Air pressure (front /rear)	kPa	1020/1020

*本公司保留更改产品设计和规格的权利，恕不另行通知。
HELI products specification and design are subject to improvement and change without notice.



Jl. Inspeksi Kalimalang KM. 22 Blok A Gudang A-01,
Cibuntu, Bekasi - 17530
Telp : (021) 8953 5873
Mobile : +62 819 555 5969
Email : thubastunggalperkasa@gmail.com
Website : www.thubastunggalperkasa.co.id



Jl. Inspeksi Kalimalang KM. 22 Blok A Gudang A-01,
Cibuntu, Bekasi - 17530
Telp : (021) 8953 5873
Mobile : +62 819 555 5969
Email : thubastunggalperkasa@gmail.com
Website : www.thubastunggalperkasa.co.id



集装箱空箱堆高机

CPCD250EC7
CPCD250EC8

EMPTY CONTAINER HANDLER



EMPTY CONTAINER HANDLER

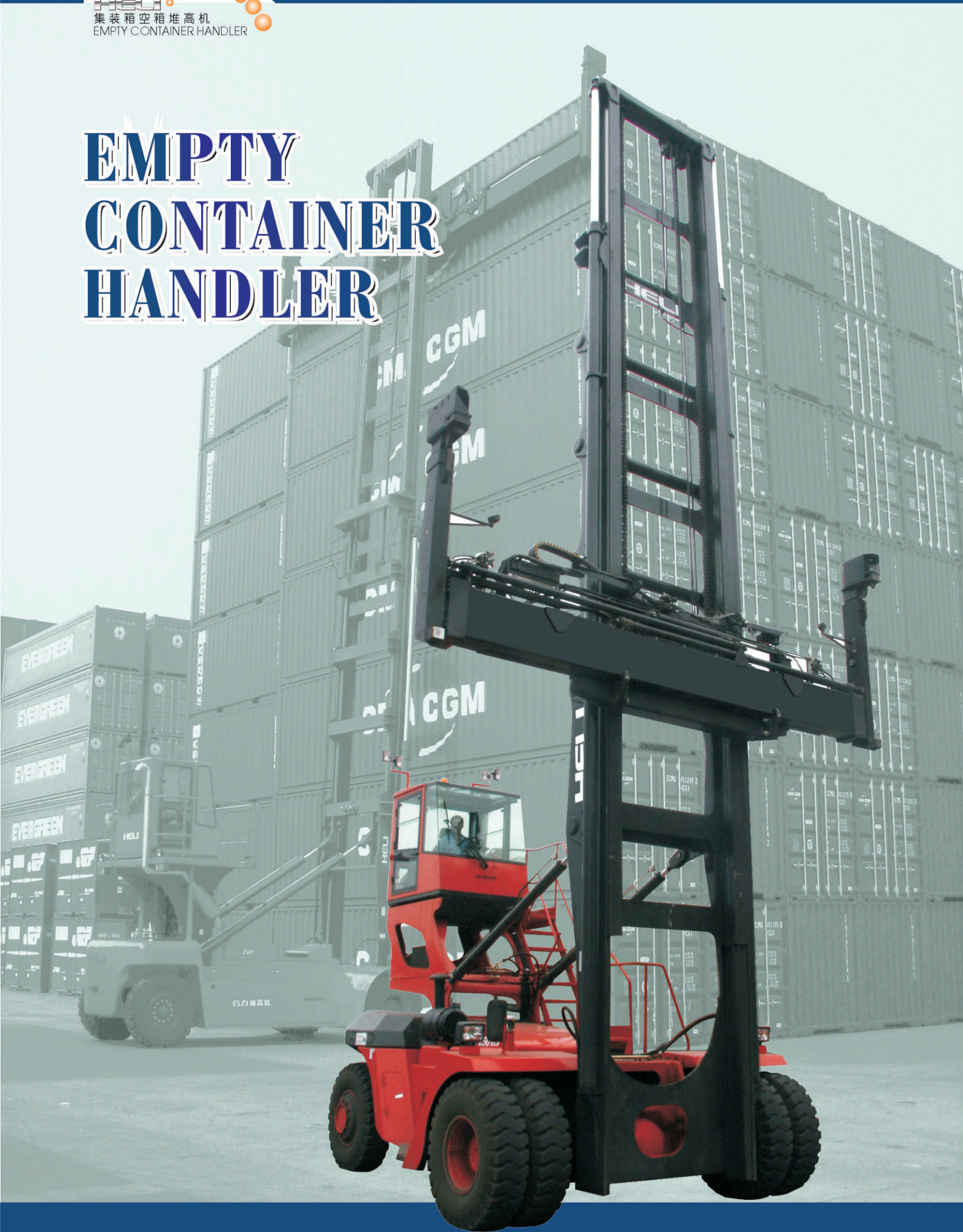

设计手段: 在整机的研制过程中借助计算机技术, 运用了最新的设计方法和手段; 车架、门架等关键结构件均经CAE有限元分析、模态分析、动力学仿真分析等优化设计手段, 以精准的理论数据支持为设计基础, 确保整车稳定性和结构强度均符合欧盟设计标准。

Design means: The latest design method and means are applied with the help of computer technology in the research and development course of the complete machine. The key structures like frame and gantry etc have undergone the optimum design means such as CAE finite element analysis, modal analysis and dynamics simulation analysis etc and take the accurate theoretic data support as their design base so that the stability and the structure strength of the whole car conform to the European design standard.

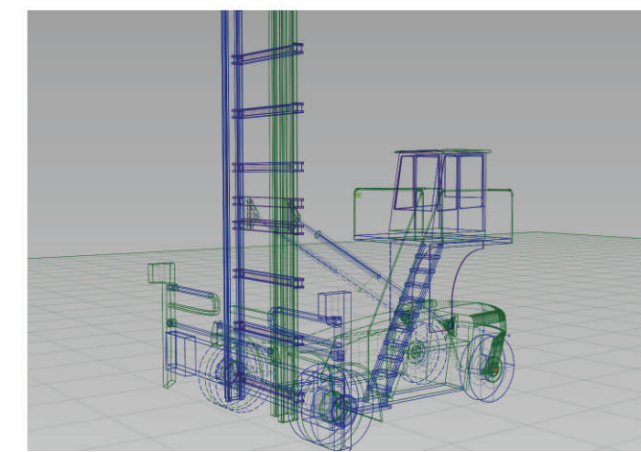
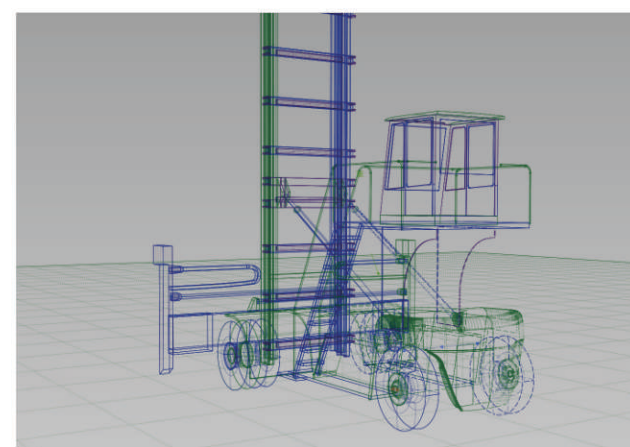



发动机: 采用瑞典VOLVO公司柴油机, 6缸涡轮增压, 功率、扭矩大, 适合全天候作业, 高性能、低油耗、符合欧2排放标准。

发动机所用附件如空滤器、消声器均为专用配置, 提高发动机的使用寿命与可靠性。

热平衡温度好: 在环境温度40度状态下, 发动机水热平衡温度控制在105℃以下, 传动油热平衡温度控制在90℃以下, 液压油热平衡温度控制在90℃以下, 较好的解决了因密封件老化导致的漏油漏水、发动机的早期磨损、变速箱无力(动力传递不足)等常见故障, 各系统部件都能在良好的温度条件下工作, 提高了整车的可靠性, 降低故障率。

驱动桥: 采用德国KESSLER公司的重载驱动桥(包含停车制动器), 该桥桥荷、制动扭矩大, 安全可靠; 制动器为多片式湿式制动器, 全封闭免维护安全可靠, 配备有钳盘式停车制动器。

Drive axle: The heavy-duty drive axle (including parking brake) of KESSLER Company, Germany is used. The axle, with large capacity and brake torque, is safe and reliable. The multiple-piece wet type is fully enclosed, maintenance free, safe and reliable and is equipped with caliper disc parking brake.

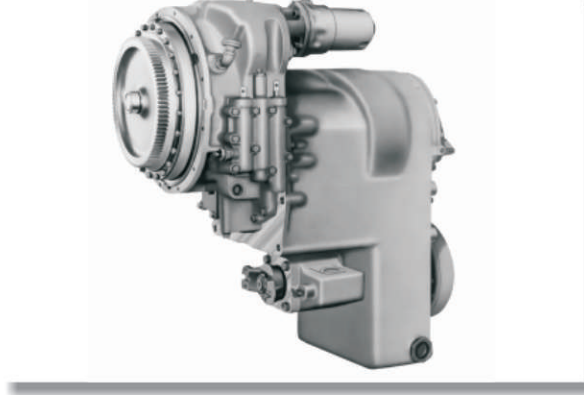

Engine: The diesel engines and 6 cylinder turbocharger of VOLVO Company, Sweden are used respectively. With great power and torque, it is suitable for all-weather operation. High in performance and low in oil consumption, it meets the class 2 emission standard of Europe. All the auxiliaries of the engine such as air filter and silencer are specially configured in order to prolong the service life and improve the reliability of the engine.

Good thermal equilibrium temperature : Under the ambient temperature of 40 °C, the water thermal equilibrium temperature of the engine is controlled below 105 °C, the thermal equilibrium temperature of drive oil under 90 °C and the thermal equilibrium temperature of the hydraulic oil under 90 °C, which can solve in a better way the common problems of oil and water leakage due to the aging of the sealing elements, earlier abrasion of the engine and incapable gear box(power transmission is insufficient) etc so that the elements of all systems can work under the good temperature condition , thus raising the reliability of the whole car and lowering the fault rate.

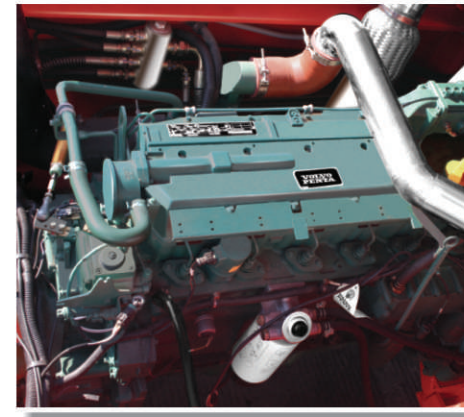
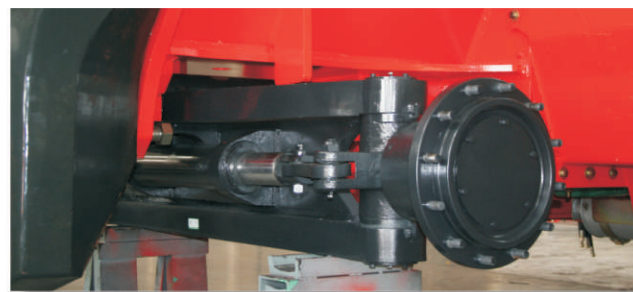

变速箱与变矩器: 采用美国DANA公司产品(原CLARK变速箱), 该变速箱采用多种控制程序集成于一体控制部件, 能轻易实现各种控制操纵, 并带有故障诊断仪, 大大简化了维护与保养。变矩器最大变矩比为2.13, 高效范围宽, 油耗少。

Gearbox and torque converter: The products (original CLARK gear box) of DANA Company, USA are used. The gear box adopts the control parts that integrate various kinds of control programs and can easily realize various control manipulations .It is furnished with fault diagnostic apparatus, greatly simplifying the maintenance. The maximum torque ratio of the torque converter is 2.13. It has high efficiency, wide range and less oil consumption.

液压系统: 采用美国PARKER公司产品, 高效可靠, 单手柄操纵, 先导远程控制, 操纵轻便, 简单省力, 可减轻司机的操作疲劳强度; 液压油路配强制冷却系统, 可满足高强度作业的要求。

全液压负荷传感的定量泵系统
合理的系统设计确保节能高效
转向器、优先阀美国EATON公司
控制阀/管路/接头/滤油器/油箱呼吸器/密封圈原装派克进口件。

Hydraulic system: The products of PARKER Company, USA is used, which, both efficient and reliable, is operated with single handle and piloted control. It can relieve the fatigue of the drivers because of simple operation and energy saving. The hydraulic oil circuit equipped with forced cooling system can meet the requirements of high intensity work.

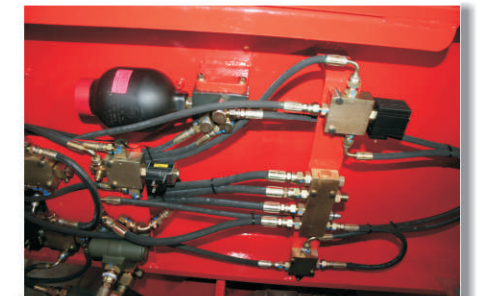

油门操纵采用液压油门操纵器, 发动机加速更顺畅, 操纵动作更轻便, 系统更耐久可靠。全液压力转向, 带负荷传感功能, 横置油缸式转向桥, 转向更灵活, 轻巧。

The accelerator is operated with hydraulic accelerator manipulator so that the acceleration of the engine is smoother, the operation action more handy and the system is durable and reliable.



全液压力制动系统: 制动阀、充液阀等制动元件选用美国MICO公司产品; 接头、胶管等管路元件选用美国PARKER公司产品, 配有多级安全保护装置, 安全可靠。
行车制动低压报警
过温报警
系统堵塞报警

Fully-hydraulic dynamic braking system: The braking elements such as brake valve and replenishing valve etc use the products from MICO Company of USA. The connectors and rubber pipes etc choose the products from PARKER Company, USA and equipped with multi-stage protection devices, so they are safe and reliable..
Service brake low pressure alarm
Over-temperature alarm
System obstruction alarm

电气系统: 控制部分采用模块化、高度集成的DVEC(双中央配电盒)设计, 应用先进的可编程3D矩阵技术, 方便变更, 使用AMP(安普)和DELPHI(德尔福)接插件, 具有较好的防尘、防溅功能。设计简单明了, 性能安全可靠, 同时预留了多个可根据用户需要进行功能扩展的接口, 减少潜在故障点, 提高系统的可靠性。

模块化设计, 减少故障点, 提高可靠性
防尘、防水

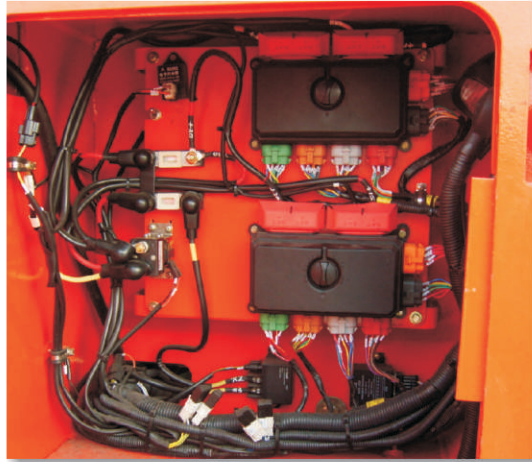

Electric system: The control parts adopts modular and highly integrated DVEC (double central distribution box) design. With advanced programmable 3D matrix technology, it is easy to alter. The connectors made by AMP and DELPHI have good dust-proof and splash-proof functions. The design is simple and clear and performance is safe and reliable. Meanwhile, the interfaces can be pre-reserved for the function extension needed by the users, thus reducing the potential fault points and raising the reliability of the system.

Modular design to reduce the fault points and raise the reliability

Dust and water resistance



散热系统: 采用进口德国AKG品牌散热器, 该散热器应用油水复合技术, 单层布置, 便于冲洗和保养, 优越的散热性能确保各系统部件都能在良好的温度条件下工作, 有效的降低了整车故障率, 提高整车可靠性。

发动机水、中冷、变速箱油各自独立的复合散热器 自动钎焊技术, 铝质散热器, 质量可靠, 散热功率大

Heat radiation system: AKG brand radiator imported from German is used, which applies water and oil compound technology, is arranged in single layer and facilitates flushing and maintenance. The superior heat dissipation performance ensures that the parts of each system can work under the good temperature condition, thus effectively cutting down the fault rate and raising the reliability of the whole car.

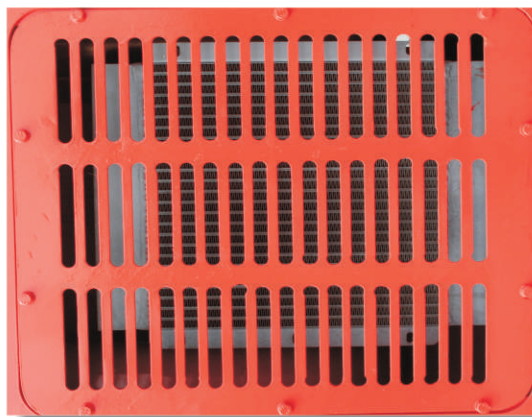

驾驶室内座椅采用全悬浮减震结构, 可做全方位的调节; 各操作踏板、手柄位置按人体工程学原理设计, 可大大降低劳动强度; 加大司机室设计, 四面全明玻璃, 视野开阔, 配冷暖空调。

The drive seat in the drive cab adopts full suspension and vibration attenuation structure and can be adjusted in all directions. Each operation pedals and handle position are designed according to the principle of human engineering and can greatly reduce the labor intensity. The drive cab is designed with transparent glasses on all sides and wide field of vision and is furnished with air conditioner as well.





利用优化设计手段进行加宽门架设计，改善了整车的视野，同时增加了门架的抗扭性，起升下降更加平稳可靠。

To broaden the gantry design by making use of the optimum design means, which improves the field of vision of the whole car and strengthens the resistance to torsion of gantry as well so that the ascending and descending are more smooth and reliable.

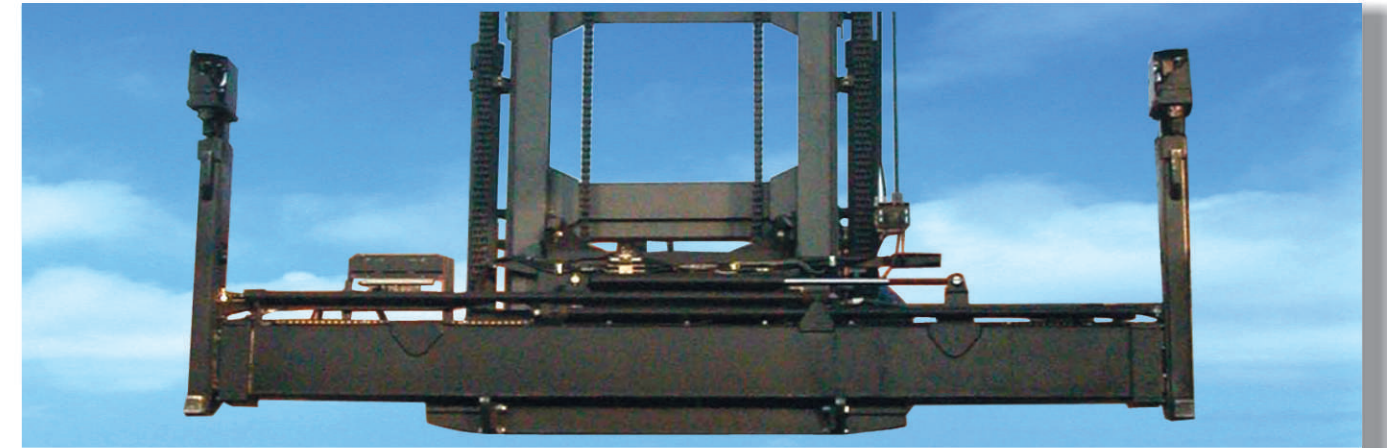
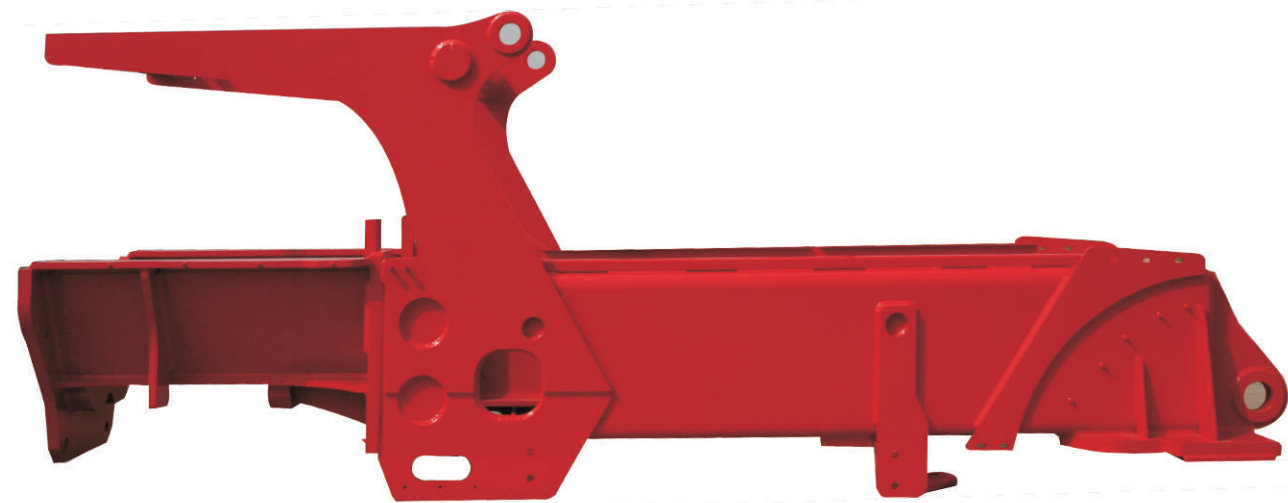

吊具：采用瑞典ELME公司的新型吊具，该吊具采用优质钢制造，单筒式结构，强度高，视野好，带安全互锁功能。可实现侧移、伸缩和开闭锁等动作，并有吊具状态指示，辅助灯光照明等功能。

Spreader: The new type spreader from ELME Company, Sweden is used, which is made with high quality steel and of single-tube structure and has high strength, good field of vision and safe interlocking function. It can realize the actions of sideways, expansion, contraction, unlocking and locking etc and has the functions of spreader status indicator and auxiliary lamplight lighting etc.



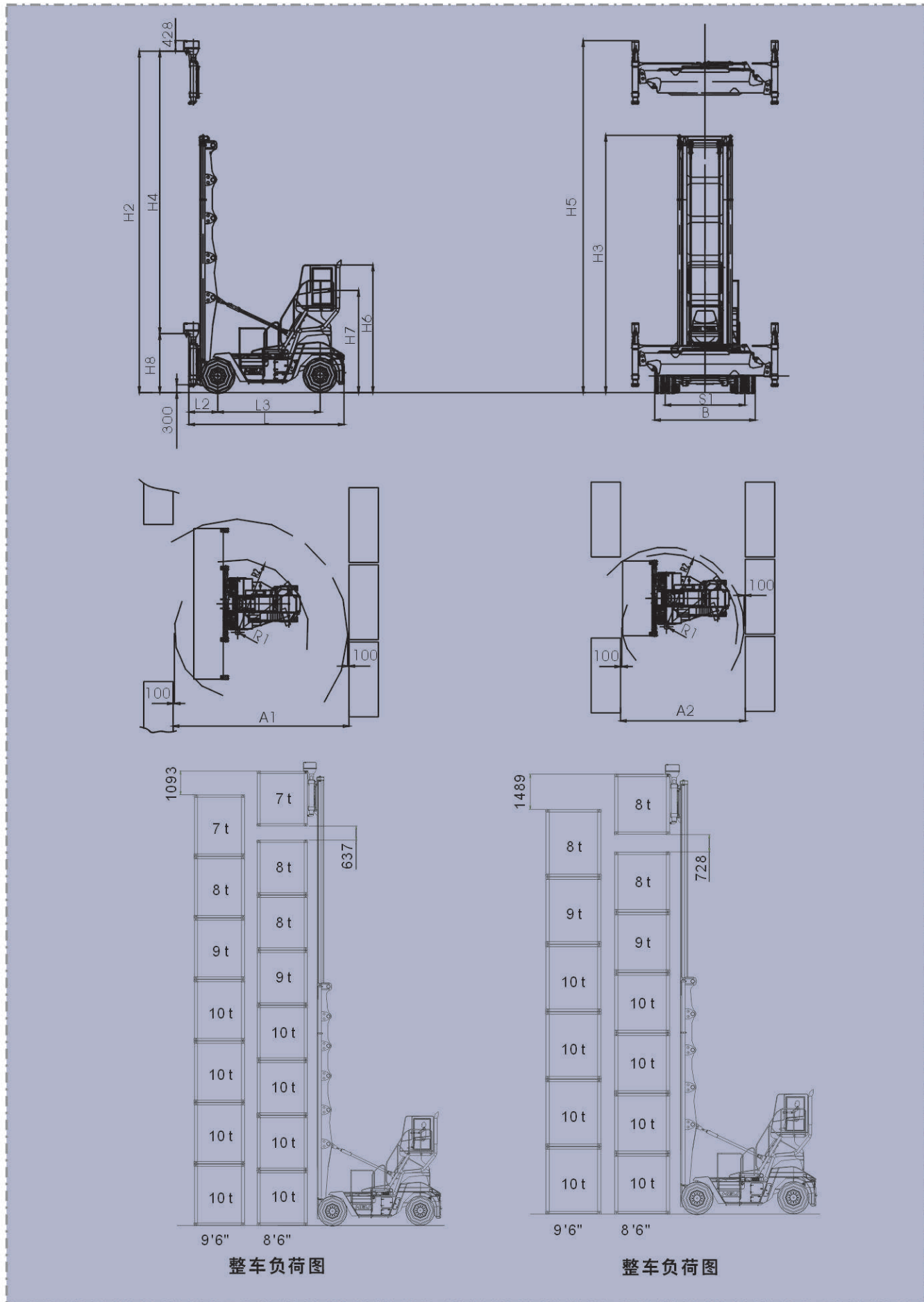

现场使用灵活，轻巧。

Flexible and handy operation on site

