

# 8FB

## Series

1.0ton / 1.35ton / 1.5ton / 1.75ton / 2.0ton / 2.5ton / 3.0ton / 3.5ton



Features and equipment may vary depending on region.

### SAS&OPS plus



Solid Stability For Travel & Load Handling  
**OPT Active Control Rear Stabilizer\***



An onboard computer monitors the movement of the forklift and locks the swing of the rear axle when necessary, such as during turns.

Note: Active Control Rear Stabilizer is not installed when the forklift is originally equipped with optional dual front tires.

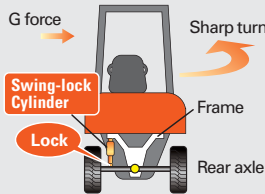

\*Note: Not available when equipped with optional dual tires.

Helping to Prevent Load Spills  
**OPT Active Mast Function Controller**

**Active Mast Front-tilt Angle Control**  
The angle of forward mast tilt is automatically controlled to match the lift height and load weight, helping to prevent load spills or tip-over.

**Active Mast Tilt Speed Control**  
Helps to prevent load spills by automatically controlling mast tilt speed at high mast height.



Smooth and Stable Operation  
**NEW Automatic turn-speed control**

**OPT** This controls turn speed according to the lift height, load weight, and turning radius, providing stable turning matched to the state of operation.

#### Turning Without Load

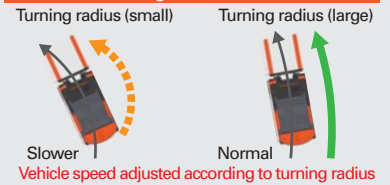

#### Turning With Load



The system uses a switch sensor built into the operator's seat to detect the presence of the operator. If the operator is not in the proper operating position, travel power is interrupted and load-handling operations are stopped.  
Note: OPS does not operate the brakes. Always set the parking brake before leaving the forklift.

### Longer Operating Hours

#### Longer Operating Time

Newly developed motors and motor-drivers minimize the energy loss, and minimized heat generation greatly reduces energy consumption, achieving longer operating time.

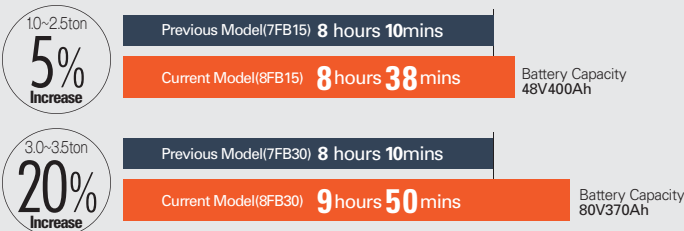

Comparison of operating times based on Toyota operating cycle with same battery capacity. Assuming that the forklift is actually operated in 55% of total working hours (100% discharge).

### Water Resistance

**NEW** High Water Resistance(IPX4)

Through its structure and the layout of motors and controllers, the new 8FB series achieved high water resistance, complied with IPX4\*. This enables 8FB series to be used at a wide range of worksites.



\*According to internal research

## Operability

### NEW LED Headlights

**OPT** The economical LED lights offer long life and low energy consumption. Also able to withstand jolts and vibration to a high degree, they are resistant to broken elements even when traveling on bumpy surfaces.

LED Headlights



LED Rear Combination Lights



### NEW LED Blue Light

**OPT** A blue beam of light appears on the ground to inform pedestrians of the forklift's presence, and helps prevent accidents.



Irradiated Area of the Floor



**Low and Wide Step**

**Solid Stability**

Powerful yet compact AC motors allow the battery to be placed under the toeboard, realising the outstanding stability.

### OPT Rear-Pillar Assist Grip

This assist grip with horn button enhances reverse travel comfort and offers easy horn operation while traveling backwards.



### NEW Orange Seat Belt

**OPT** When this option is selected, the color of the seat belt will be orange, making it easier to confirm if the seat belt is securely fastened.



### NEW Seat Belt Interlock System

**OPT** Travel power will be interrupted and load-handling operations will be stopped if the seat belt is not securely fastened after the operator is properly seated.

Note: When this option is selected, the color of the seatbelt will be orange.

**Roomy Leg Space**

Designed to provide plenty of space to enhance the operator's comfort and reduce fatigue.

## MAIN SPECIFICATIONS

Features and equipment may vary depending on region.

Model		8FB10 [8FBH10]	8FB14 [8FBH14]	8FB15 [8FBH15]	40-8FB15	8FB18 [8FBH18]	8FB20 [8FBH20]	40-8FB20
Load Capacity	kg	1,000	1,350	1,500	1,500	1,750	2,000	2,000
Load Center	mm	500	500	500	500	500	500	500
Overall Width	A mm	1,060	1,060	1,115	1,160	1,115	1,160	1,230
Turning Radius (Outside)	B mm	1,750	1,760	1,770	1,980	1,780	1,980	2,145
Overhead Guard Height	C mm	2,025 [2,105]	2,025 [2,105]	2,025 [2,105]	2,105	2,025 [2,105]	2,025 [2,105]	2,160
Length to Fork Face	D mm	2,075	2,080	2,080	2,215	2,115	2,240	2,405

Model		8FB25 [8FBH25]	40-8FB25	8FB30	8FBJ35
Load Capacity	kg	2,500	2,500	3,000	3,500
Load Center	mm	500	500	500	500
Overall Width	A mm	1,160	1,230	1,240	1,240
Turning Radius (Outside)	B mm	2,000	2,170	2,210	2,270
Overhead Guard Height	C mm	2,025 [2,105]	2,160	2,195	2,195
Length to Fork Face	D mm	2,290	2,435	2,490	2,575

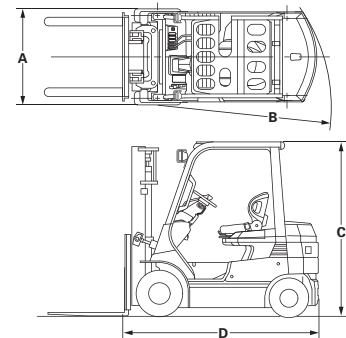

## BATTERY AND MOTOR SPECIFICATIONS

Model		8FB10 8FB14	8FB15 8FB18	8FBH10 8FBH14 8FBH15 8FBH18	40-8FB15	8FB20	8FB25	8FBH20 8FBH25	40-8FB20 40-8FB25	8FB30 8FBJ30	
Voltage/Capacity (5-hour ratings)	STD	V/Ah	48 / 330	48 / 400	48 / 545	48 / 600	48 / 450	48 / 565	48 / 730	48 / 845	80 / 370
	High	V/Ah	48 / 485	48 / 485	—	48 / 730	48 / 600	48 / 600	—	—	80 / 470
Electric Motors	Drive	kW	7.6	7.6	7.6	10.7	10.7	10.7	10.7	10.7	11.9
	Load Handling	kW	9.5	9.5	9.5	12.2	12.2	12.2	12.2	12.2	14.4

The data in this brochure was determined based on our standard testing condition. Operating performance may vary depending on the actual specifications and condition of the vehicle, as well as the conditions of the operating area. Due to photography and printing, color of actual vehicle may vary from this brochure. Some photos have been computer-enhanced. Availability and specifications are determined regionally and are subject to change without notice. Safe forklift operation is achieved by proper operator training and proper worksite rules. Please consult your Toyota representative regarding forklift selection and operator training. Please consult your Toyota representative for details.

All rights reserved by Toyota Industries Corporation.



Pergudangan Lautan Jaya Kumala, Jl. Inspeksi Kalimantan KM. 22 Blok A Gudang A-01, Cibuntu, Bekasi-17520

Telp : (021) 89535873  
Mobile : 0817-0555-969  
Email : thubastunggalperkasa@gmail.com  
Website : www.thubastunggalperkasa.co.id



TOYOTA MATERIAL HANDLING INTERNATIONAL

LF.8FB10-J35 (E)/E-1611/©No.711540E0/800