

Standard Size Figure

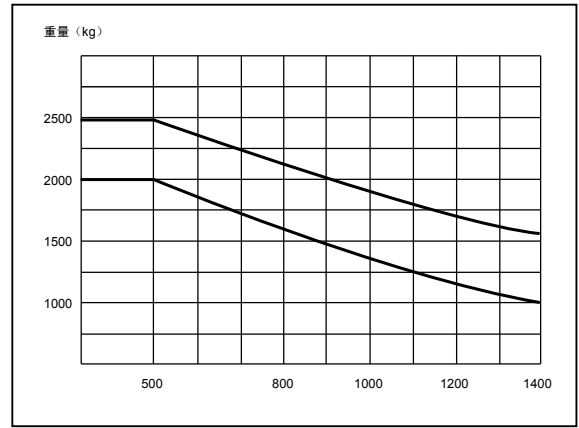
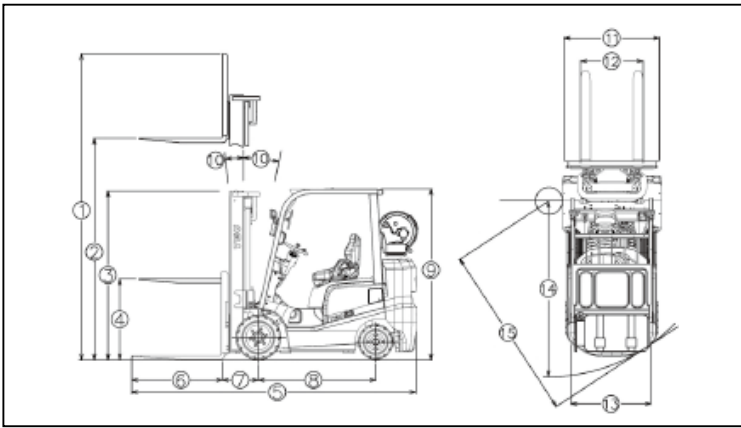

Standard Size

Specification	1		Manufacturer		TEU					
	2		Model		FCG20T	FCG25T				
Specification	3		Load capacity		kg	2000	2500			
	4		Load center		mm	500				
	5		Power unit		LPG					
	6		Operator type		Seat					
	7		Tire type		front/rear	Cushion Tires				
	8		Wheels		front/rear	2/2				
	9		Max.lifting height		mm	3000				
	10		Free lift		mm	160				
Dimensions	11		Fork size L×W×T		mm	1070×122×40				
	12		Tilt angle (forward/ backward)		deg	6/6				
	13		Overall Length (without fork)		mm	2278	2328			
	14		Total Width		mm	1174				
	15		Mast height (fork lowerd)		mm	2006				
	16		Overall height fork raised (with backrest)		mm	4030				
	17		Height of head guard		mm	2035				
	18		Turning raduis(outside)		mm	2002	2500			
	19		Load distance(fork front face to front axle)		mm	442				
	20		Min. right angle stacking aisle(adding no load length and clearance)			2450	2500			
Performance	21		Max. travelling		full load/no load	km/h		17.5/18		
	22		Speed		Lifting	full load/no load	mm/s		550/580	
	23		Lowering		full load/no load	mm/s		450/550		
Weights	24		Weight		kg	3445	3795			
	25		Weight distribution		No load	front axle/rear axle	kg		1380/2065	1345/2450
	26		Full load		front axle/rear axle	kg		4730/715	5532/763	
Chassis & Wheels	27		Tires		Front/rear	16.25×6×11.25 / 21×8×15				
	28		Wheelbase		mm	1400				
	29		Tread		Front/rear	mm		970/950		
	30		Ground Clearance		At lowest point(mast)	mm		110/116		
	31		Brake		Hydraulic					
Drive Line	32		Engine		Model	NISSANK21		NISSANK25EPA		
			Rated power		KW/rpm	31.2/2250		42.2/2700		
			Rated torque		N-m/rpm	144/1600		155/1600		
			Number of cylinder		4					
			Displacement		L	2.065		2.488		
	33		Fuel tank capacity		L	50				
34		Transmission		Power shift T/M			Hydraulic Torque Transmission			
35		Transmission shift		Speed forward /backward			1/1-Electromagnetic Hydraulic			
36		Hydraulic sysem pressure		kg/cm ²	180					

※ Products and specifications change without prior notice

FCG

Series 20-25

TEU

**Cushion Tires
Counter Balanced Forklift**

**Doc+or
FORKLIFT**



Three Features

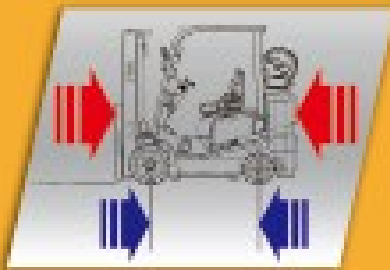

1 Flexible Operation

Compared with FD25T, total length of the truck is shortened 220mm, wheelbase shortened 200mm and turning radius shortened 210mm, which makes the operation more flexible and suitable for using in narrow space.

2 Lower Emission

Equipped with powerful and efficient EFI, EPA approved engine — Nissan K25(optional).



3 Novel and Fashionable Appearance

Inherited the design of the family style, fashionable and dynamic appearance, capacious driving space, and easy maintenance .