



Doc+or
FORKLIFT



EP14N2T
EP16CN2T
EP18CN2T
EP16N2T
EP18N2T
EP20N2T

EP16CN2
EP18CN2
EP16N2
EP18N2
EP20N2

POWERFULLY AGILE

SPECIFICATIONS

ELECTRIC POWERED LIFT TRUCKS 48V, 1.4 - 2.0 TONNES



TUNED IN TO THE DRIVER

THIS INTELLIGENT FORKLIFT'S ADVANCED FEATURES MAKE DRIVING AND LOAD HANDLING EASIER, STEADIER, SAFER AND MORE COMFORTABLE. DRIVERS FEEL THE MACHINE IS TOTALLY IN TUNE WITH THEM, SO THEY ARE HAPPY, CONFIDENT AND HIGHLY PRODUCTIVE.



360° steering option gives greater agility in turning. This allows the truck to turn and move in the opposite direction (180°) without stopping, and avoids destabilising the load (3 wheel model).



Responsive Drive System 2 (RDS2) reacts instantly to changes in the speed of pedal and hydraulic control movement. It means all actions are smoothly controlled, including cornering behaviour, stops and starts.



Load-sensing hydraulic system automatically adjusts to the weight being handled, to maintain precise control. Passive sway control keeps the automatic parking brake open so mast sway energy is absorbed by the mass of the whole truck. All masts and low-friction side-shift minimise sway, twisting and noise.



The adjustable seat and steering column assure a perfect driving position for drivers of all sizes. Forward, downward and side views are excellent due to a specially designed free lift cylinder structure where hoses and chains are positioned to minimise obstacles to vision. Ergonomic controls include an adjustable armrest, with inbuilt fingertip levers, and a set of low-fatigue pedals.

LOWER COST OF OPERATION

- Efficient motors with high RPM range give better precision in acceleration control, create more torque at low speeds and reduce energy consumption.
- Fully electronic magnetic brakes require less servicing and offer greater energy efficiency.
- Robust construction and sealed components reduce maintenance needs.
- Durable hose and hydraulic cylinder sealing specification withstands high temperature range, weathering and physical wear.
- Fast battery compartment access speeds up servicing and exchanges.
- Easy-to-read multi-function colour display encourages correct use and maintenance of truck.
- Modular design simplifies addition or replacement of parts, including overhead guard and cabin options.
- Li-ion battery option adds even greater efficiency and runtime, along with minimal maintenance needs and much longer life, for lower long-term total cost of operation (TCO).

UNMATCHED PRODUCTIVITY

- *Responsive Drive System 2 (RDS2)* traction tuning adapts performance rapidly in reaction to speed of pedal operation, and ensures all movements, stops and starts are smooth.
- *Responsive Drive System 2 (RDS2)* mast tuning adjusts constantly to the driver's hydraulic control behaviour, ensuring optimally matched functionality, sensitivity and reaction speed for the best possible operator experience.
- *PowerBurst* automatically delivers extra torque to maintain ramp speed or provide strong acceleration, even when carrying heavy loads.
- Variable steering ratio and steering force are continuously optimised for different travel speeds.
- Advanced curve control co-ordinates the two front-wheel drive motors and rear steer axle motor to optimise turning speed, stabilise fast sideways movements of the counterweight, and prevent tilting when straightening after high-speed turns.
- Dual drive '4-wheel steering' with a +100° rear turning axle provides smooth and agile manoeuvring, including instant side turns with no need to push back.
- 360° steering option enables fluid turning without stopping to change direction (3 wheel).
- Electric differential lock option maximises grip on slippery surfaces by locking front wheels to increase traction (activated automatically at small steering angles or manually via an optional pedal function).
- Optional *SmoothFlow* hydraulic system automatically adjusts to load weight, ensuring fast but smooth and precise control of all mast and fork actions - whether individual or simultaneous.
- Passive sway control keeps automatic parking brake open during lifts, so mast sway energy can be absorbed by chassis.

- As standard, truck acceleration and hydraulic performance is automatically limited at lifts from 3.5 metres for steady, controlled handling. As an option, this feature can be set to activate at lifts above 2 metres.
- High-specification masts and low-friction side-shift minimise sway, twisting and noise.
- Pre-set ECO and PRO modes can be selected for different drivers and tasks, or customised settings can be applied by service engineers.
- Li-ion option enhances performance and permits fast opportunity charging for continuous operation without battery changes.

SAFETY AND ERGONOMICS

- Market-leading *SilentRun+* hydraulic pumps (optional) plus quiet drive units and other low-noise technologies keep driver comfortable and stress-free, increase awareness of surrounding activity and avoid disturbing neighbours and co-workers.
- Extended seat and steering column adjustability assures a comfortable driving position, and enables good vision with no need to lean forward.
- Spacious operator compartment offers comfort and easy access features for drivers of all sizes.
- Inclined and narrow dashboard, one-spoke steering wheel and optimised free lift cylinder structure maximise forward, downward and side visibility.
- Spring-force-optimised fingertip hydraulic controls on adjustable armrest ensure ergonomically perfect hand positioning, anatomical support and free movement.
- Pedal design, position and angles reduce fatigue for drivers of any height or foot size.
- Steering knob automatically returns to convenient 8 o'clock position when truck drives straight, even if the wheel has been overturned.
- Dual joystick option separates functions such as clamp opening, to avoid accidental moves, and is especially useful if fingertip levers are too small for operation with gloves (or large hands).
- *ErgoSense* single joystick option offers anatomically optimised design and multi-function control layout for efficient operation with minimal fatigue.
- *Palm Steering* option offers enhanced forward view, relaxed driving position and operation with minimal effort – ideal if driver is seated for long periods.
- Low-noise gearbox improves conditions for drivers and their colleagues.
- Presence Detection System+ includes automatic parking brake, hill hold and – if operator is not seated – prevention of travel and hydraulic movement.
- Flashing brake light option warns others of slowdown when accelerator pedal released, and is replaced by steady light when brake pedal pressed.
- Safety lights (optional) include red lines, highlighting exclusion boundary around truck, and red or blue spots (front and rear) warning pedestrians of truck's approach.

STANDARD EQUIPMENT AND OPTIONS

GENERAL	3 WHEEL 48V						4 WHEEL 48V				
	EP14N2T	EP16CN2T	EP18CN2T	EP16N2T	EP18N2T	EP20N2T	EP16CN2	EP18CN2	EP16N2	EP18N2	EP20N2
3 and 4 wheel chassis, 48 volts, front wheel drive	●	●	●	●	●	●	●	●	●	●	●
Operator-selectable economy or high performance modes ECO/PRO	●	●	●	●	●	●	●	●	●	●	●
Multifunctional colour display (hour meter, BDI etc.)	●	●	●	●	●	●	●	●	●	●	●
Lift tilt interlock and hydraulic and drive interlock / PDS	●	●	●	●	●	●	●	●	●	●	●
Tiltable steering column	●	●	●	●	●	●	●	●	●	●	●
Fully electric brakes	●	●	●	●	●	●	●	●	●	●	●
Battery compartment side door and opening battery hood cover	●	●	●	●	●	●	●	●	●	●	●
SST (Seat Switch Timeout: all functions are disabled – truck enters 'stop mode' and park brake is automatically applied)	●	●	●	●	●	●	●	●	●	●	●
Basic overhead guard	●	●	●	●	●	●	●	●	●	●	●
Trucktool set-up and diagnostics	●	●	●	●	●	●	●	●	●	●	●
Dual joysticks	○	○	○	○	○	○	○	○	○	○	○
<i>Palm Steering</i>	○	○	○	○	○	○	○	○	○	○	○
<i>ErgoSense</i> joystick	○	○	○	○	○	○	○	○	○	○	○
Rapid sideways battery exchange chassis (SWE)	○	○	○	○	○	○	○	○	○	○	○
Chassis-integrated roller bed (for battery SWE)	○	○	○	○	○	○	○	○	○	○	○
Special (RAL) colour for frame	○	○	○	○	○	○	○	○	○	○	○
POWER SOURCE											
Li-ion battery*	○	○	○	○	○	○	○	○	○	○	○
Lead-acid battery	○	○	○	○	○	○	○	○	○	○	○
HYDRAULIC											
3 valve hydraulic fingertip control mounted on adjustable armrest	●	●	●	●	●	●	●	●	●	●	●
4th and 5th hydraulic options	○	○	○	○	○	○	○	○	○	○	○
Manual lever hydraulic control	○	○	○	○	○	○	○	○	○	○	○
Hydraulic accumulator for smoother load handling on rough surfaces	○	○	○	○	○	○	○	○	○	○	○
<i>SilentRun+</i> hydraulic pumps	○	○	○	○	○	○	○	○	○	○	○
MAST, FORKS AND CARRIAGE											
Load backrest	●	●	●	●	●	●	●	●	●	●	●
Passive sway control for mast at high lifts	●	●	●	●	●	●	●	●	●	●	●
Simplex, duplex or triplex masts, from 3m to 7m	○	○	○	○	○	○	○	○	○	○	○
Forks 900mm - 2000mm	○	○	○	○	○	○	○	○	○	○	○
Sideshifter W920mm	○	○	○	○	○	○	○	○	○	○	○
Integrated sideshifter W920mm	○	○	○	○	○	○	○	○	○	○	○
Integrated fork positioner with sideshift	○	○	○	○	○	○	○	○	○	○	○
Load weight indicator, in 50kg increments	○	○	○	○	○	○	○	○	○	○	○
Performance reduction from 2m to 3.5m mast (above standard)	○	○	○	○	○	○	○	○	○	○	○
DRIVE AND LIFT CONTROLS											
Variable speed control on all hydraulic functions	●	●	●	●	●	●	●	●	●	●	●
Curve control	●	●	●	●	●	●	●	●	●	●	●
Armrest direction control	●	●	●	●	●	●	●	●	●	●	●
Electronic differential lock	○	○	○	○	○	○	○	○	○	○	○
Automatic tilt centring via the F2 button on fingertip controller	○	○	○	○	○	○	○	○	○	○	○
Tilt centring second function. Two pcs. of angle memories	○	○	○	○	○	○	○	○	○	○	○
Forward-reverse direction selection lever on steering column	○	○	○	○	○	○	○	○	○	○	○
Dual pedal system - forward and reverse	○	○	○	○	○	○	○	○	○	○	○
Operator presence pedal	○	○	○	○	○	○	○	○	○	○	○

● Standard ○ Option

* Li-ion battery option is available in selected regions.

For more information about standard and available optional equipment, please contact your dealer.

STANDARD EQUIPMENT AND OPTIONS CONTINUED

	3 WHEEL 48V						4 WHEEL 48V				
	EP14N2T	EP16CN2T	EP18CN2T	EP16N2T	EP18N2T	EP20N2T	EP16CN2	EP18CN2	EP16N2	EP18N2	EP20N2
ELECTRIC											
LED working lights, 2 front and 1 rear	●	●	●	●	●	●	●	●	●	●	●
Automatic reversing light	●	●	●	●	●	●	●	●	●	●	●
Automatic light switch	○	○	○	○	○	○	○	○	○	○	○
Amber strobe light	○	○	○	○	○	○	○	○	○	○	○
Road light kit	○	○	○	○	○	○	○	○	○	○	○
Electronic smart reversing alarm	○	○	○	○	○	○	○	○	○	○	○
'Blue point' safety light, located rear and/or front	○	○	○	○	○	○	○	○	○	○	○
Red line safety lights, located on the sides	○	○	○	○	○	○	○	○	○	○	○
Pin code access	○	○	○	○	○	○	○	○	○	○	○
5V USB connector output 2 x 2.5A (max 4.4A)	○	○	○	○	○	○	○	○	○	○	○
240W, 12V power supply for accessories	○	○	○	○	○	○	○	○	○	○	○
OHG AND CABIN											
Grammer MSG65 vinyl with seat belt switch	●	●	●	●	●	●	●	●	●	●	●
Grammer MSG65 or MSG75 with options vinyl / cloth / heater / backrest extension / armrest (MSG65)	○	○	○	○	○	○	○	○	○	○	○
Swivel seat	○	○	○	○	○	○	○	○	○	○	○
Plexi roof cover	○	○	○	○	○	○	○	○	○	○	○
Panel cabin: front screen with wiper + roof with crane opening	○	○	○	○	○	○	○	○	○	○	○
Panel cabin: economy - front screen without wiper, plexi roof cover	○	○	○	○	○	○	○	○	○	○	○
Panel cabin steel doors	○	○	○	○	○	○	○	○	○	○	○
Panel cabin rear screen	○	○	○	○	○	○	○	○	○	○	○
PVC doors	○	○	○	○	○	○	○	○	○	○	○
Heater for cabin	○	○	○	○	○	○	○	○	○	○	○
Interior package, including radio with speakers, roof lining, reading light	○	○	○	○	○	○	○	○	○	○	○
Deluxe cabin, including windscreen with wiper, roof, steel doors, heater and interior lining	○	○	○	○	○	○	○	○	○	○	○
Rear view mirror, basic / outside / wide view	○	○	○	○	○	○	○	○	○	○	○
List bracket - A4	○	○	○	○	○	○	○	○	○	○	○
Storage plastic locker	○	○	○	○	○	○	○	○	○	○	○
Sun visor	○	○	○	○	○	○	○	○	○	○	○
Accessory rack	○	○	○	○	○	○	○	○	○	○	○
RAM-mounts dummy, D-series	○	○	○	○	○	○	○	○	○	○	○
RAM-mounts computer rack, C-series	○	○	○	○	○	○	○	○	○	○	○
RAM-mounts scanner rack, C-series	○	○	○	○	○	○	○	○	○	○	○
Powder fire extinguisher	○	○	○	○	○	○	○	○	○	○	○
Narrow overhead guard for drive-in racking	○	○	○	○	○	○	○	○	○	○	○
TYRES											
Solid pneumatic tyres	●	●	●	●	●	●	●	●	●	●	●
Solid non-marking tyres	○	○	○	○	○	○	○	○	○	○	○
ENVIRONMENT											
Hot area hydraulic oil, VG46	○	○	○	○	○	○	○	○	○	○	○
Cold area hydraulic oil, VG15	○	○	○	○	○	○	○	○	○	○	○
Hydraulic oil food grade	○	○	○	○	○	○	○	○	○	○	○
Bio grade oil	○	○	○	○	○	○	○	○	○	○	○
Cold store option (to -35°C)	○	○	○	○	○	○	○	○	○	○	○

● Standard ○ Option

For more information about standard and available optional equipment, please contact your dealer.

Characteristics		
1.1	Manufacturer	
1.2	Manufacturer's model designation	
1.3	Power source: (battery, diesel, LP gas, petrol)	
1.4	Operator type: pedestrian, standing, seated	
1.5	Load capacity	Q (kg)
1.6	Load centre distance	c (mm)
1.8	Load distance, axle to fork face	x (mm)
1.9	Wheelbase	y (mm)
Weight		
2.1	Truck weight, without load / including battery (simplex mast, lowest lift height)	kg
2.2	Axle loading with maximum load, front/rear (simplex mast, lowest lift height)	kg
2.3	Axle loading without load, front/rear (simplex mast, lowest lift height)	kg
Wheels, Drive Train		
3.1	Tyres: V=solid, L=pneumatic, SE=solid pneumatic - front/rear	
3.2	Tyre dimensions, front	pcm/ (mm)
3.3	Tyre dimensions, rear	
3.5	Number of wheels, front/rear (x=driven)	
3.6	Track width (centre of tyres), front	b10 (mm)
3.7	Track width (centre of tyres), rear	b11 (mm)
Dimensions		
4.1	Mast tilt, forwards/backwards	α/β °
4.2	Height with mast lowered (see tables)	h1 (mm)
4.3	Free lift (see tables)	h2 (mm)
4.4	Lift height (see tables)	h3 (mm)
4.5	Overall height with mast raised	h4 (mm)
4.7	Height to top of overhead guard	h6 (mm)
4.8	Seat height	h7 (mm)
4.12	Tow coupling height	h10 (mm)
4.19	Overall length	l1 (mm)
4.20	Length to fork face (includes fork thickness)	l2 (mm)
4.21	Overall width	b1/b2 (mm)
4.22	Fork dimensions (thickness, width, length)	s / e / l (mm)
4.23	Fork carriage to DIN 15 173 A/B/no	
4.24	Fork carriage width	b3 (mm)
4.31	Ground clearance under mast, with load	m1 (mm)
4.32	Ground clearance at centre of wheelbase, with load (forks lowered)	m2 (mm)
4.33	Working aisle width with 1000 x1200 mm pallets, crosswise	Ast (mm)
4.34a	Working aisle width with 800 x1200 mm pallets, lengthwise	Ast (mm)
4.35	Turning circle radius	Wa (mm)
4.36	Minimum distance between centres of rotation	b13 (mm)
Performance		
5.1	Travel speed, with/without load	km/h
5.2	Lifting speed, with/without load	m/s
5.3	Lowering speed, with/without load	m/s
5.5	Rated drawbar pull, with/without load	N
5.6	Maximum drawbar pull, with/without load (5 min. short duty)	N
5.7	Gradeability, with/without load	%
5.8	Maximum gradeability, with/without load	%
5.9	Acceleration time (10 metres) with/without load	s
5.10	Service brakes (mechanical/hydraulic/electric/pneumatic)	
Electric Motors		
6.1	Drive motor capacity (60 min. short duty)	kW
6.2	Lift motor output at 15% duty factor	kW
6.3	Battery to DIN 43 531/35/36 A/B/C/no	
6.4	Battery voltage/min-max capacity	V/Ah
6.5	Battery weight	kg
6.6a	Energy consumption according to EN 16796	kWh/h
Miscellaneous		
8.1	Type of drive control	AC
8.2	Maximum operating pressure for attachments	bar
8.3	Oil flow for attachments	l/min
8.4	Noise level, value at operator's ear (EN 12053)	dB(A)
8.5	Towing coupling design / DIN type, ref.	

Cat Lift Trucks	Cat Lift Trucks	Cat Lift Trucks	Cat Lift Trucks	Cat Lift Trucks	Cat Lift Trucks
EP14N2T	EP16CN2T	EP18CN2T	EP16N2T	EP18N2T	EP20N2T
Electric	Electric	Electric	Electric	Electric	Electric
Seated	Seated	Seated	Seated	Seated	Seated
1400	1600	1800	1600	1800	2000
500	500	500	500	500	500
343	343	343	343	343	358
1320	1320	1320	1428	1428	1428
2790	2966	3156	2949	3119	3342
3688/502	4015/551	4351/605	4020/529	4333/586	4711/631
1394/1396	1393/1573	1401/1754	1476/1474	1471/1649	1509/1833
SE	SE	SE	SE	SE	SE
18x7-8	18x7-8	18x7-8	18x7-8	18x7-8	200/50-10
140/55-9	140/55-9	140/55-9	140/55-9	140/55-9	140/55-9
2 x / 2	2 x / 2	2 x / 2	2 x / 2	2 x / 2	2 x / 2
930	930	930	930	930	938
174	174	174	174	174	174
5/7.5	5/7.5	5/7.5	5/7.5	5/7.5	5/7.5
2125	2125	2125	2125	2125	2125
80	80	80	80	80	80
3290	3290	3290	3290	3290	3290
4335	4335	4335	4335	4335	4335
2050	2050	2050	2050	2050	2050
1035	1035	1035	1035	1035	1035
540	540	540	540	540	540
2996	2996	2996	3104	3104	3119
1846	1846	1846	1954	1954	1969
1090	1090	1090	1090	1090	1140
35x100x1150	35x100x1150	35x100x1150	35x100x1150	35x100x1150	35x100x1150
2A	2A	2A	2A	2A	2A
920	920	920	920	920	920
95	95	95	95	95	95
95	95	95	95	95	95
3173	3173	3173	3281	3281	3295
3296	3296	3296	3404	3404	3419
1502	1502	1502	1610	1610	1610
0	0	0	0	0	0
2x5.5	2x5.5	2x5.5	2x5.5	2x5.5	2x5.5
10	10	10	10	10	10
DIN 43531 A/no	DIN 43531 A/no	DIN 43531 A/no	DIN 43531 A/no	DIN 43531 A/no	DIN 43531 A/no
500-625	500-625	500-625	625-750	625-750	625-750
679	679	679	812	812	812
3.7	3.9	4.2	3.9	4.2	4.5
AC	AC	AC	AC	AC	AC
210	210	210	210	210	210
30	30	30	30	30	30
65	65	65	65	65	65
DIN15170-H	DIN15170-H	DIN15170-H	DIN15170-H	DIN15170-H	DIN15170-H

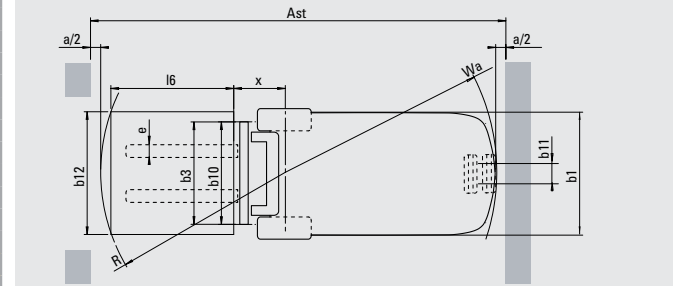
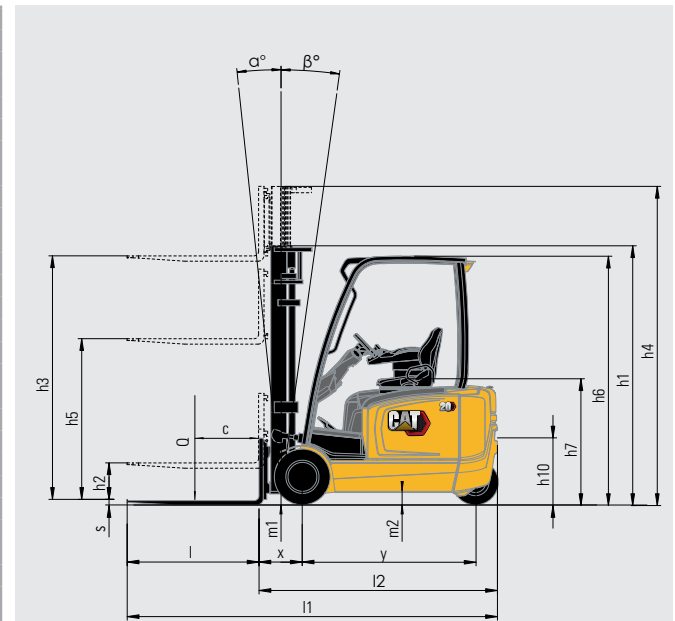

$Ast = Wa + R + a$
 $Ast = \text{Working aisle width}$
 $Wa = \text{Turning radius}$
 $a = \text{Safety clearance} = 2 \times 100 \text{ mm}$
 $R = \sqrt{(l6 + x)^2 + (b12 / 2)^2}$
 $l6 = \text{Pallet length (800 or 1000 mm)}$
 $b12 = \text{Pallet width (1200 mm)}$

This specification sheet provides details of the standard truck specification in accordance with VDI Guideline 2198.

Characteristics		
1.1	Manufacturer	
1.2	Manufacturer's model designation	
1.3	Power source: (battery, diesel, LP gas, petrol)	
1.4	Operator type: pedestrian, standing, seated	
1.5	Load capacity	Q (kg)
1.6	Load centre distance	c (mm)
1.8	Load distance, axle to fork face	x (mm)
1.9	Wheelbase	y (mm)
Weight		
2.1	Truck weight, without load / including battery (simplex mast, lowest lift height)	kg
2.2	Axle loading with maximum load, front/rear (simplex mast, lowest lift height)	kg
2.3	Axle loading without load, front/rear (simplex mast, lowest lift height)	kg
Wheels, Drive Train		
3.1	Tyres: V=solid, L=pneumatic, SE=solid pneumatic - front/rear	
3.2	Tyre dimensions, front	pcm/ (mm)
3.3	Tyre dimensions, rear	
3.5	Number of wheels, front/rear (x=driven)	
3.6	Track width (centre of tyres), front	b10 (mm)
3.7	Track width (centre of tyres), rear	b11 (mm)
Dimensions		
4.1	Mast tilt, forwards/backwards	α/β °
4.2	Height with mast lowered (see tables)	h1 (mm)
4.3	Free lift (see tables)	h2 (mm)
4.4	Lift height (see tables)	h3 (mm)
4.5	Overall height with mast raised	h4 (mm)
4.7	Height to top of overhead guard	h6 (mm)
4.8	Seat height	h7 (mm)
4.12	Tow coupling height	h10 (mm)
4.19	Overall length	l1 (mm)
4.20	Length to fork face (includes fork thickness)	l2 (mm)
4.21	Overall width	b1/b2 (mm)
4.22	Fork dimensions (thickness, width, length)	s / e / l (mm)
4.23	Fork carriage to DIN 15 173 A/B/no	
4.24	Fork carriage width	b3 (mm)
4.31	Ground clearance under mast, with load	m1 (mm)
4.32	Ground clearance at centre of wheelbase, with load (forks lowered)	m2 (mm)
4.33	Working aisle width with 1000 x1200 mm pallets, crosswise	Ast (mm)
4.34a	Working aisle width with 800 x1200 mm pallets, lengthwise	Ast (mm)
4.35	Turning circle radius	Wa (mm)
4.36	Minimum distance between centres of rotation	b13 (mm)
Performance		
5.1	Travel speed, with/without load	km/h
5.2	Lifting speed, with/without load	m/s
5.3	Lowering speed, with/without load	m/s
5.5	Rated drawbar pull, with/without load	N
5.6	Maximum drawbar pull, with/without load (5 min. short duty)	N
5.7	Gradeability, with/without load	%
5.8	Maximum gradeability, with/without load	%
5.9	Acceleration time (10 metres) with/without load	s
5.10	Service brakes (mechanical/hydraulic/electric/pneumatic)	
Electric Motors		
6.1	Drive motor capacity (60 min. short duty)	kW
6.2	Lift motor output at 15% duty factor	kW
6.3	Battery to DIN 43 531/35/36 A/B/C/no	
6.4	Battery voltage/min-max capacity	V/Ah
6.5	Battery weight	kg
6.6a	Energy consumption according to EN 16796	kWh/h
Miscellaneous		
8.1	Type of drive control	AC
8.2	Maximum operating pressure for attachments	bar
8.3	Oil flow for attachments	l/min
8.4	Noise level, value at operator's ear (EN 12053)	dB(A)
8.5	Towing coupling design / DIN type, ref.	

Cat Lift Trucks	Cat Lift Trucks	Cat Lift Trucks	Cat Lift Trucks	Cat Lift Trucks
EP16CN2	EP18CN2	EP16N2	EP18N2	EP20N2
Electric	Electric	Electric	Electric	Electric
Seated	Seated	Seated	Seated	Seated
1600	1800	1600	1800	2000
500	500	500	500	500
343	343	343	343	358
1394	1394	1502	1502	1502
2944	3114	2957	3097	3287
3990/554	4311/603	4008/550	4295/603	4668/620
1422/1522	1422/1692	1510/1448	1484/1613	1525/1762
SE	SE	SE	SE	SE
18x7-8	18x7-8	18x7-8	18x7-8	200/50-10
16x6-8	16x6-8	16x6-8	16x6-8	16x6-8
2 x / 2	2 x / 2	2 x / 2	2 x / 2	2 x / 2
930	930	930	930	938
898	898	898	898	898
5/7.5	5/7.5	5/7.5	5/7.5	5/7.5
2125	2125	2125	2125	2125
80	80	80	80	80
3290	3290	3290	3290	3290
4335	4335	4335	4335	4335
2050	2050	2050	2050	2050
1035	1035	1035	1035	1035
520	520	520	520	520
3152	3152	3260	3260	3275
2002	2002	2110	2110	2125
1090	1090	1090	1090	1140
35x100x1150	35x100x1150	35x100x1150	35x100x1150	35x100x1150
2A	2A	2A	2A	2A
920	920	920	920	920
95	95	95	95	95
95	95	95	95	95
3333	3333	3441	3441	3455
3456	3456	3564	3564	3579
1662	1662	1770	1770	1770
0	0	0	0	0
17/17	17/17	17/17	17/17	17/17
0.52/0.62	0.46/0.62	0.52/0.62	0.46/0.62	0.42/0.62
0.56/0.56	0.56/0.56	0.56/0.56	0.56/0.56	0.56/0.56
4900/5200	4800/5100	4900/5200	4800/5100	4700/5100
14900/15200	14900/15200	15000/15300	14900/15200	14800/15200
15/25	14/23	15/26	14/23	12/21
27/35	26/35	27/35	26/35	24/35
4.1/3.8	4.2/3.8	4.0/3.8	4.2/3.8	3.9/4.4
Electric	Electric	Electric	Electric	Electric
2x5.5	2x5.5	2x5.5	2x5.5	2x5.5
10	10	10	10	10
DIN 43531 A/no	DIN 43531 A/no	DIN 43531 A/no	DIN 43531 A/no	DIN 43531 A/no
500-625	500-625	625-750	625-750	625-750
679	679	679	812	812
3.9	4.2	3.9	4.2	4.5
AC	AC	AC	AC	AC
210	210	210	210	210
30	30	30	30	30
65	65	65	65	65
DIN15170-H	DIN15170-H	DIN15170-H	DIN15170-H	DIN15170-H

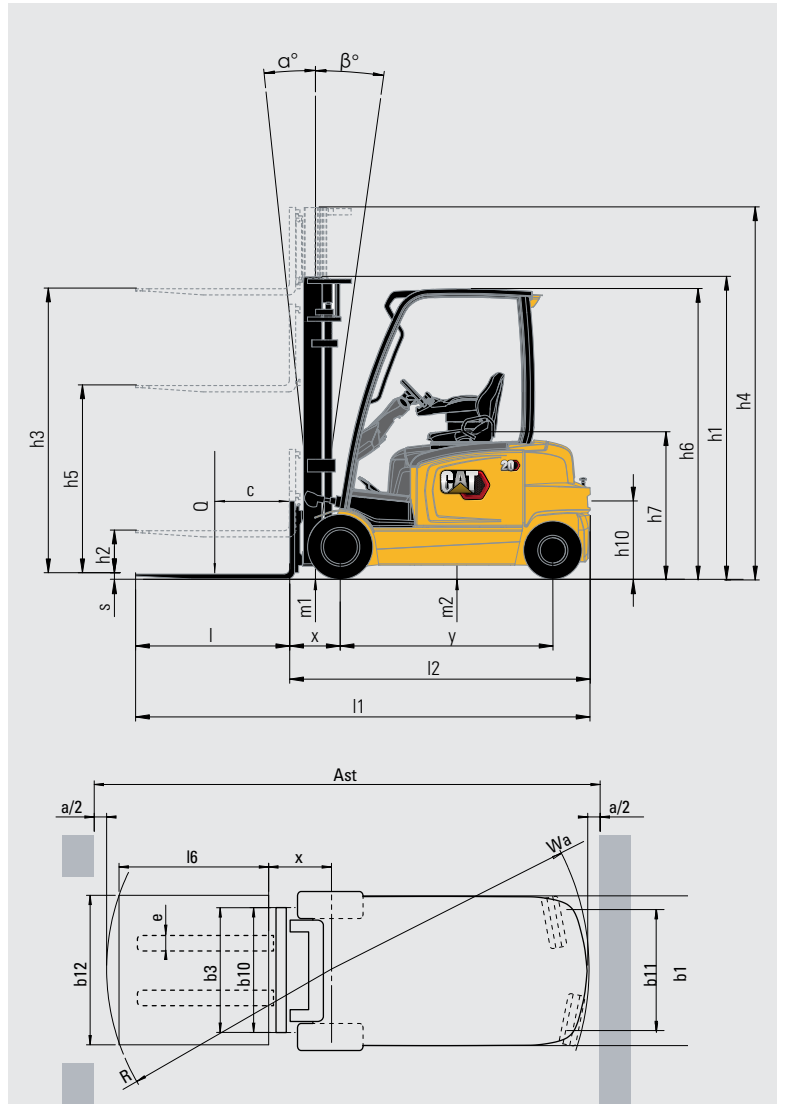

$Ast = Wa + R + a$
 $Ast = \text{Working aisle width}$
 $Wa = \text{Turning radius}$
 $a = \text{Safety clearance} = 2 \times 100 \text{ mm}$
 $R = \sqrt{(l6 + x)^2 + (b12 / 2 - b13)^2}$
 $l6 = \text{Pallet length (800 or 1000 mm)}$
 $b12 = \text{Pallet width (1200 mm)}$

This specification sheet provides details of the standard truck specification in accordance with VDI Guideline 2198.

LI-ION BATTERIES

TIME TO SWITCH?



Lithium-ion (Li-ion) battery technology is available in the Cat® electric counterbalance and warehouse truck ranges. While lead-acid batteries remain a popular choice for our customers, and still have much to offer, they present various challenges which Li-ion can overcome.

Perhaps the most noticeable change when switching to Li-ion is the use of opportunity charging. Instead of exchanging batteries between shifts, you can simply plug into a fast charger during short breaks and keep the same battery going 24/7. This, together with other efficiency, environmental and safety benefits, makes Li-ion a very appealing alternative.

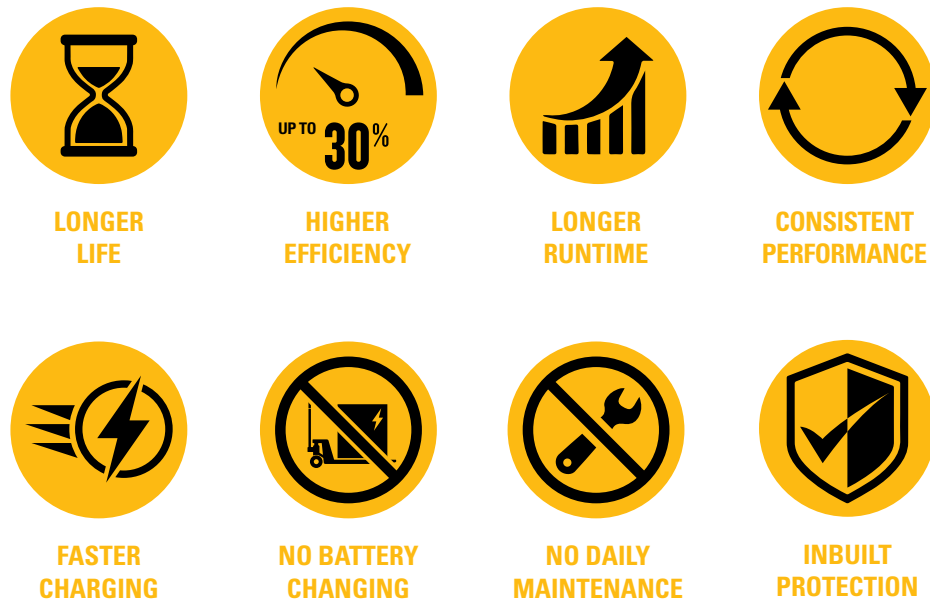

Cat Li-ion advantages over lead-acid

Li-ion is an investment which should be viewed against ongoing savings on energy, equipment, labour and downtime.

- **Longer life** – 3 to 4 times lead-acid lifespan – reduces overall battery investment
- **Higher efficiency** – energy losses during charging and discharging are up to 30% lower, so electricity consumption is reduced
- **Longer runtime** – thanks to more efficient battery performance and use of opportunity charges, which can be given at any time without damaging the battery or shortening its lifespan
- **Consistently high performance** – with a more constant voltage curve – maintains greater truck productivity, even toward the end of a shift
- **Faster charging** – enables full charge in as little as 1 hour with the fastest chargers
- **No battery changing** – fast opportunity charges – 15 minutes for several hours of extra runtime – enable continuous operation with just one battery and minimise the need to buy, store and maintain spares
- **No daily maintenance** – the battery stays on board the truck for charging and there is no need for water top-ups or electrolyte checks
- **No gas** – or acid spills – avoids the space, equipment and running costs of a battery room and ventilation system
- **Inbuilt protection** – intelligent battery management system (BMS) automatically prevents excessive discharge, charge, voltage and temperature, as well as virtually eliminating misuse

Batteries and chargers with different capacities are available. Your dealer will identify the best combination for your needs. You should also ask your dealer about optional 5-year warranties, subject to annual check-ups, which give extra peace of mind.

info@catliftruck.com | www.catliftruck.com

CEESC2240(08/22) © 2022 MLE B.V. (registration no. 33274459). All rights reserved. CAT, CATERPILLAR, LET'S DO THE WORK, their respective logos, "Caterpillar Yellow", the "Power Edge" and Cat "Modern Hex" trade dress as well as corporate and product identity used herein, are trademarks of Caterpillar and may not be used without permission.

NOTE: Performance specifications may vary depending on standard manufacturing tolerances, vehicle condition, types of tyres, floor or surface conditions, applications, or operating environment. Trucks may be shown with non-standard options. Specific performance requirements and locally available configurations should be discussed with your Cat lift trucks Dealer. Cat Lift Trucks follows a policy of continual product improvement. For this reason, some materials, options and specifications could change without notice.



Pergudangan Lautan Jaya Kumala, Jl. Inspeksi Kalimantan KM. 22 Blok A Gudang A-01, Cibuntu, Bekasi-17520

Telp : (021) 89535873
Mobile : 0817-0555-969
Email : thubastunggalperkasa@gmail.com
Website : www.thubastunggalperkasa.co.id