

Doc+or  
**FORKLIFT**



DP60N3  
DP70N3  
DP80N3  
DP100N3

**POWERFUL AND DURABLE**

**SPECIFICATIONS**

**ENGINE POWERED LIFT TRUCKS 6.0 - 10.0 TONNES**



# POWERFUL AND DURABLE

DRIVEN BY ONE OF THE MOST POWERFUL ENGINES IN ITS CLASS, THE DP60-100N3 BOASTS BOTH STRENGTH AND SPEED. THE MASSIVE LOADS IT CAN HANDLE DO NOT HAMPER ITS SPEED, MAKING THIS ONE OF THE FASTEST AND MOST EFFICIENT MACHINES IN THE INDUSTRY.



Its 3.8L common rail diesel engine delivers high power with minimal vibration transmitted to the driver's seat, due to the use of cushioning materials between its frame and engine.

A variety of attachments are available, including different carriages and side shifters.



Typical applications include:

- Stevedoring
- Empty container handling
- Metal industries
- Lumber
- Concrete, stone, clay and glass
- Industrial machinery and equipment
- Distribution centres
- Brick and stone

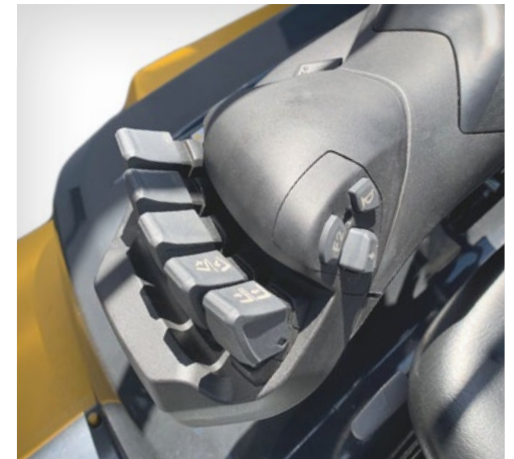

The optional adjustable armrest combines anatomical support with free movement and perfect hand positioning. It features spring-force-optimised fingertip hydraulic controls.

## LOWER COST OF OWNERSHIP

- Powerful 3.8L common rail diesel engine delivers strong performance with rapid acceleration and low fuel consumption.
- Dependable engine and tough truck components that resist damage and wear help to minimise repair and service bills.
- Quick and easy access to all components for routine checks and maintenance makes it easier to keep the truck in sound working condition, saving time and reducing expense.

## UNMATCHED PRODUCTIVITY

- One of the highest lift speeds in its class lets your operators achieve greater output per shift.
- Automatic, 2-speed powershift transmission offers controlled yet powerful acceleration for maximum productivity.
- Automotive pedal layout enables easy and intuitive operation.
- Low footstep and well-placed grab handle makes on/off access easy.
- Extremely rigid mast with a thoughtfully designed roller layout offers excellent visibility.
- Boltless floorboards can be easily removed, without any tools, for easy maintenance.
- Durable LED lights are included as standard equipment.
- Optional cabin keeps your operators comfortable and productive in the most extreme temperatures and in wet environments - keeping the elements out, without compromising visibility.

## SAFETY AND ERGONOMICS

- Mast with narrow channels, combined with high-visibility overhead guard, gives the operator clear views forwards and upwards.
- Presence Detection System (PDS) gives audible warning if seat belt is not fastened and prevents all travel and hydraulic movement if operator is not correctly seated.
- Reversing alarm is supplied as standard.
- Conveniently placed grab bars and steps ease access to operator compartment.
- Ergonomically shaped Grammer seat with back cushion gives optimal lateral support and driver comfort.

## OPTIONS

- Wide range of attachments available
- Cabin
- Fingertip hydraulic controls with adjustable armrest
- Speedometer
- Status monitor
- Torque converter oil temperature/pressure gauge
- Wide range of tyres can be tailored to your requirements
- Various front and rear work light solutions



# STANDARD EQUIPMENT AND OPTIONS

	DIESEL			
	DP60N3	DP70N3	DP80N3	DP100N3
<b>GENERAL OPTIONS</b>				
Default canvas roof	○	○	○	○
Headguard deletion	○	○	○	○
2 rear view mirrors (OHG mounted)	●	●	●	●
Rear view mirror centre mounted	○	○	○	○
Large size rear view mirror	○	○	○	○
Heater driver's area	○	○	○	○
Tilt cylinder boots	○	○	○	○
Tilt cylinder cover	○	○	○	○
Power steering boots	○	○	○	○
Fingertip lever hydraulic control	○	○	○	○
<b>HYDRAULIC CONTROL</b>				
2-way control valve MC	●	●	●	●
3-way control valve MC	○	○	○	○
4-way control valve MC	○	○	○	○
5-way control valve MC	○	○	○	○
3-way control valve FC	○	○	○	○
4-way control valve FC	○	○	○	○
5-way control valve FC	○	○	○	○
<b>MAST, FORKS AND CARRIAGE</b>				
Loose mast	○	○	○	○
Carriage wide –simplex	●	●	●	●
Carriage extra wide –simplex	○	○	○	○
Integral sideshifter for shaft type forks – simplex	○	○	○	○
Integral sideshifter for hook type forks – triplex	○	○	○	○
<b>ELECTRIC</b>				
Load weight indicator (cannot be combined with ARMDC)	○	○	○	○
Mast tilt gauge	○	○	○	○
Status monitor (checks battery fluid, air cleaner dust and coolant status)	○	○	○	○
High volume back-up buzzer	○	○	○	○
Torque converter temperature gauge	○	○	○	○
Wide range rear working lights	○	○	○	○
Wide range of strobe lights	○	○	○	○
Wide range front working lights	○	○	○	○
Rear LED red line warning light (activated by reverse lever)	○	○	○	○
Back-up handle with horn button	○	○	○	○
<b>TYRES</b>				
Pneumatic dual tyre-drive- / single tyre-steer-	●	●	●	●
Solid pneumatic dual tyre-drive- / single tyre-steer-	○	○	○	○
Solid pneumatic dual tyre-drive- / single tyre-steer- (soft comp.)	○	○	○	○
Solid pneumatic dual tyre-drive- / single tyre-steer- (white)	○	○	○	○
<b>AIR INTAKE &amp; EXHAUST</b>				
Air intake pre-cleaner	○	○	○	○
Exhaust cover	○	○	○	○
CCV heater	○	○	○	○

● Standard    ○ Option

For more information about standard and available optional equipment, please contact your dealer.

Characteristics		
1.1	Manufacturer (abbreviation)	
1.2	Manufacturer's model designation	
1.3	Power source: (battery, diesel, LP gas, petrol)	
1.4	Operator type: pedestrian, (operator) -standing, -seated	
1.5	Load capacity	Q (kg)
1.6	Load center distance	c (mm)
1.8	Load distance, axle to fork face	x (mm)
1.9	Wheelbase	y (mm)
Weight		
2.1	Truck weight, without load / including battery (simplex mast, lowest lift height)	kg
2.2	Axle loading with maximum load, front/rear (simplex mast, lowest lift height)	kg
2.3	Axle loading without load, front/rear (simplex mast, lowest lift height)	kg
Wheels, Drive Train		
3.1	Tyres: V=solid, L=pneumatic, SE=solid pneumatic - front / rear	
3.2	Tyre dimensions, front	
3.3	Tyre dimensions, rear	
3.5	Number of wheels, front / rear (x = driven)	
3.6	Track width (centre of tyres), front	b10 (mm)
3.7	Track width (centre of tyres), rear	b11 (mm)
Dimensions		
4.1	Mast tilt, forwards/backwards	∂/β °
4.2	Height with mast lowered (see tables)	h1 (mm)
4.3	Free lift (see tables)	h2 (mm)
4.4	Lift height (see tables)	h3 (mm)
4.5	Overall height with mast raised	h4 (mm)
4.7	Height to top of overhead guard	h6 (mm)
4.8	Seat height	h7 (mm)
4.12	Tow coupling height	h10 (mm)
4.19	Overall length	l1 (mm)
4.20	Length to fork face (includes fork thickness)	l2 (mm)
4.21	Overall width	b1/b2 (mm)
4.22	Fork dimensions (thickness, width, length)	s / e / l (mm)
4.23	Fork carriage to DIN 15 173 A/B/no	
4.24	Fork carriage width	b3 (mm)
4.31	Ground clearance under mast, with load	m1 (mm)
4.32	Ground clearance at centre of wheelbase, with load (forks lowered)	m2 (mm)
4.33	Working aisle width with 1000 x1200 mm pallets, crosswise	Ast (mm)
4.34a	Working aisle width with 800 x1200 mm pallets, crosswise	Ast (mm)
4.34b	Working aisle width with 800 x1200 mm pallets, lengthwise	Ast (mm)
4.35	Turning circle radius	Wa (mm)
4.36	Minimum distance between centers of rotation	b13 (mm)
Performance		
5.1	Travel speed, with / without load	km / h
5.2	Lifting speed, with / without load	m / s
5.3	Lowering speed, with / without load	m / s
5.5	Rated drawbar pull, with / without load	N
5.7	Gradeability, with / without load	
5.9	Acceleration time (10 metres) with / without load	%
5.10	Service brakes (mechanical / hydraulic / electric / pneumatic)	s
IC Engine		
7.1	Manufacturer / Type	
7.2	Rated / Nominal output to ISO 1585**	kW
7.3	Rated speed to DIN 70 020	rpm
7.4	Number of cylinders / cubic capacity	cm³
7.5	Fuel consumption according to VDI 60 cycle	l/h / kg/h
7.6a	Max torque	Nm
7.7a	Max torque at engine speed	rpm
Miscellaneous		
8.1	Type of drive control	
10.1	Maximum operating pressure for attachments	bar
10.2	Oil flow for attachments	l / min
10.7	Noise level, value at operator's ear (EN 12053)	dB(A)
10.8	Towing coupling design / DIN type, ref.	

Cat Lift Trucks	Cat Lift Trucks	Cat Lift Trucks	Cat Lift Trucks
DP60N3	DP70N3	DP80N3	DP100N3
Diesel	Diesel	Diesel	Diesel
Seated	Seated	Seated	Seated
6000	7000	8000	10000
600	600	600	600
615	625	720	715
2300	2300	2500	2800
8670	9540	11510	12910
13030/1640	14640/1900	17360/2150	20660/2250
3860/4810	3910/5630	5140/6370	5980/6930
L / L	L / L	L / L	L / L
8.25X15-14PR	8.25X15-14PR	9.00X20-14PR	9.00X20-14PR
8.25X15-14PR	8.25X15-14PR	9.00X20-14PR	9.00X20-14PR
4x / 2	4x / 2	4x / 2	4x / 2
1470	1470	1600	1600
1700	1700	1700	1700
6/12	6/12	6/12	6/12
2500	2500	2800	2850
205	215	205	205
3000	3000	3000	3000
4420	4420	4420	4330
2550	2550	2660	2660
1470	1470	1570	1570
520	520	600	590
4805	4875	5245	5485
3585	3655	4025	4265
2005 / -	2005 / -	2175 / -	2245 / -
60 x 150 x 1220	70 x 150 x 1220	75 x 180 x 1220	75 x 180 x 1220
4A	4A	4A	-/-
1845	1845	2015	2208
200	200	240	240
225	225	290	290
5215	5285	5630	5865
5015	5085	5430	5665
5415	5485	5830	6065
3400	3460	3710	3950
1255	1255	1290	1475
25.0 / 28.0	25.0 / 28.0	24.0 / 28.0	24.0 / 27.0
0.53 / 0.55	0.53 / 0.55	0.44 / 0.46	0.35 / 0.37
0.45 / 0.50	0.45 / 0.50	0.45 / 0.45	0.45 / 0.35
54900 / 21600	54900 / 21600	59800 / 27500	63700 / 31400
28 / 20	28 / 20	25 / 20	21 / 20
-/-	-/-	-/-	-/-
Hydraulic	Hydraulic	Hydraulic	Hydraulic
Kubota V3800	Kubota V3800	Kubota V3800	Kubota V3800
81.0	81.0	81.0	81.0
2400	2400	2400	2400
4 / 3769	4 / 3769	4 / 3769	4 / 3769
10.0	11.0	12.0	13.0
385	385	385	385
1500	1500	1500	1500
Powershift 2/2	Powershift 2/2	Powershift 2/2	Powershift 2/2
206	206	206	206
-/-	-/-	-/-	-/-
86	86	86	86
Pin	Pin	Pin	Pin

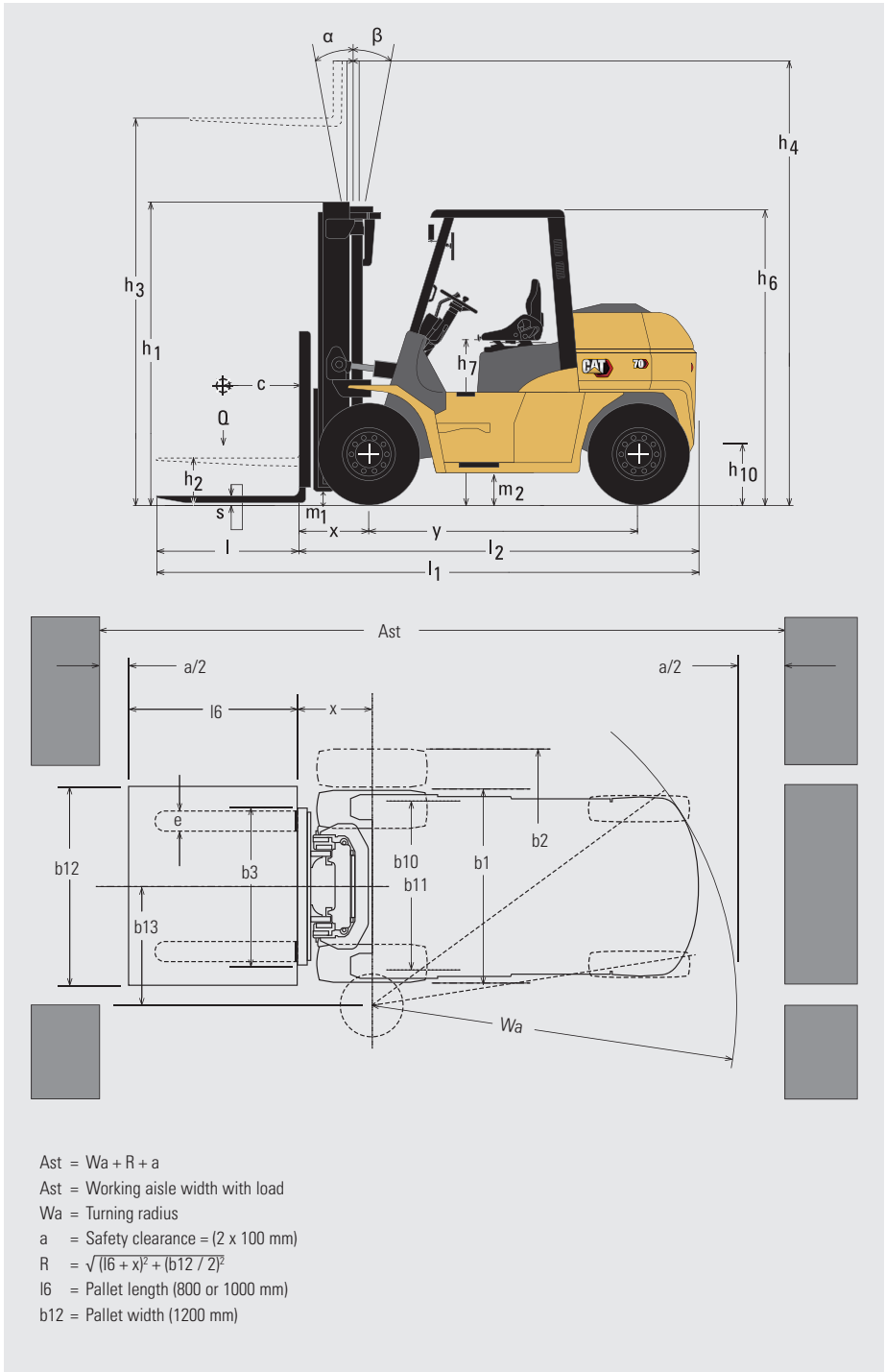

DP60N3								
Mast Type	h3 mm	h1 mm	h4 (mm)		h2/h5 (mm)		Tilt angle (fwd - back)	Q @ c=600mm kg
			With STD	Without backrest	With STD	Without backrest		
Simplex	3000	2500	4420	3950	205	205	6°/12°	6000
	3300	2650	4720	4250	205	205	6°/12°	6000
	3500	2750	4920	4450	205	205	6°/12°	6000
	4000	3050	5420	4975	205	205	6°/12°	6000
	4500	3300	5920	5475	205	205	6°/12°	6000
	5000	3550	6420	5975	205	205	6°/6°	6000
	5500	3850	6920	6525	205	205	3°/6°	5700
6000	4100	7420	7025	205	205	3°/6°	5400	
Duplex	3000	2625	4420	4095	1580	1255	6°/12°	6000
	3300	2775	4720	4395	1730	1405	6°/12°	6000
	3500	2875	4920	4595	1830	1505	6°/12°	6000
	4000	3175	5420	5095	2130	1805	6°/12°	6000
	4500	3425	5920	5595	2380	2055	6°/12°	6000
Triplex	4000	2500	5400	5075	1455	1130	6°/10°	5800
	4350	2625	5750	5425	1580	1255	6°/10°	5800
	4800	2775	6200	5875	1730	1405	6°/10°	5800
	5000	2875	6400	6075	1830	1505	6°/10°	5700
	5500	3130	6900	6575	2085	1760	3°/6°	5500
	6000	3300	7400	7075	2255	1930	3°/6°	5000
	7000	3675	8400	8075	2630	2305	3°/6°	4000
	8000	4100	9400	9075	3055	2730	3°/6°	2500

DP70N3									
Mast Type	h3 mm	h1 mm	h4 (mm)		h2/h5 (mm)		Tilt angle (fwd - back)	Q @ c=600mm kg	
			With STD	Without backrest	With STD	Without backrest			
Simplex	3000	2500	4420	4105	215	215	6°/12°	7000	
	3300	2650	4720	4405	215	215	6°/12°	7000	
	3500	2750	4920	4605	215	215	6°/12°	7000	
	4000	3050	5420	5105	215	215	6°/12°	7000	
	4500	3300	5920	5605	215	215	6°/12°	7000	
	5000	3550	6420	6105	215	215	6°/6°	7000	
	5500	3850	6920	6605	215	215	3°/6°	6600	
	6000	4100	7420	7105	215	215	3°/6°	6400	
	Duplex	3000	2625	4420	4095	1590	1265	6°/12°	7000
		3300	2775	4720	4395	1740	1415	6°/12°	7000
3500		2875	4920	4595	1840	1515	6°/12°	7000	
4000		3175	5420	5095	2140	1815	6°/12°	7000	
4500		3425	5920	5595	2390	2065	6°/12°	7000	
4000		2500	5400	5075	1465	1140	6°/10°	6800	
Triplex	4350	2625	5750	5425	1590	1265	6°/10°	6800	
	4800	2775	6200	5875	1740	1415	6°/10°	6800	
	5000	2875	6400	6075	1840	1515	6°/10°	6700	
	5500	3130	6900	6575	2095	1770	3°/6°	6400	
	6000	3300	7400	7075	2265	1940	3°/6°	6000	
	7000	3675	8400	8075	2640	2315	3°/6°	4500	
	8000	4100	9400	9075	3035	2740	3°/6°	2700	

DP80N3									
Mast Type	h3 mm	h1 mm	h4 (mm)		h2/h5 (mm)		Tilt angle (fwd - back)	Q @ c=600mm kg	
			With STD	Without backrest	With STD	Without backrest			
Simplex	3000	2800	4420	4230	205	205	6°/12°	8000	
	3300	2950	4720	4445	205	205	6°/12°	8000	
	3500	3050	4920	4645	205	205	6°/12°	8000	
	4000	3350	5420	5145	205	205	6°/12°	8000	
	4500	3600	5920	5645	205	205	6°/12°	8000	
	5000	3850	6420	6145	205	205	6°/6°	7750	
	5500	4150	6920	6645	205	205	3°/6°	7400	
	6000	4400	7420	7145	205	205	3°/6°	7000	
	Duplex	3000	2700	4420	4210	1580	1345	6°/12°	8000
		3300	2850	4720	4510	1730	1495	6°/12°	8000
3500		2950	4920	4710	1830	1595	6°/12°	8000	
4000		3250	5420	5210	2130	1895	6°/12°	8000	
4500		3500	5920	5710	2380	2145	6°/12°	8000	
4000		2575	5400	5165	1455	1220	6°/10°	7700	
Triplex	4350	2700	5750	5515	1580	1345	6°/10°	7700	
	4800	2850	6200	5965	1730	1495	6°/10°	7700	
	5000	2950	6400	6165	1830	1595	6°/10°	7600	
	5500	3205	6900	6665	2085	1850	3°/6°	7300	
	6000	3375	7400	7165	2255	2020	3°/6°	6700	
	7000	3750	8400	8165	2630	2395	3°/6°	5400	
	8000	4175	9400	9165	3055	2820	3°/6°	3500	

DP100N3								
Mast Type	h3 mm	h1 mm	h4 (mm)		h2/h5 (mm)		Tilt angle (fwd - back)	Q @ c=600mm kg
			With Standard	Without backrest	With Standard	Without backrest		
Simplex	3000	2850	-	4330	-	205	6°/12°	10000
	3300	3000	-	4630	-	205	6°/12°	10000
	3500	3100	-	4830	-	205	6°/12°	10000
	4000	3400	-	5330	-	205	6°/12°	10000
	4500	3650	-	5830	-	205	6°/12°	10000
	5000	3900	-	6330	-	205	6°/6°	10000
	5500	4200	-	6830	-	205	3°/6°	9000
	6000	4450	-	7330	-	205	3°/6°	8000

### Capacities at various load centres

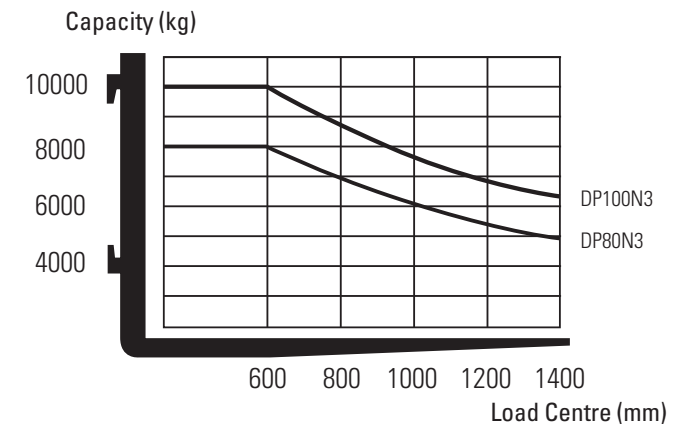
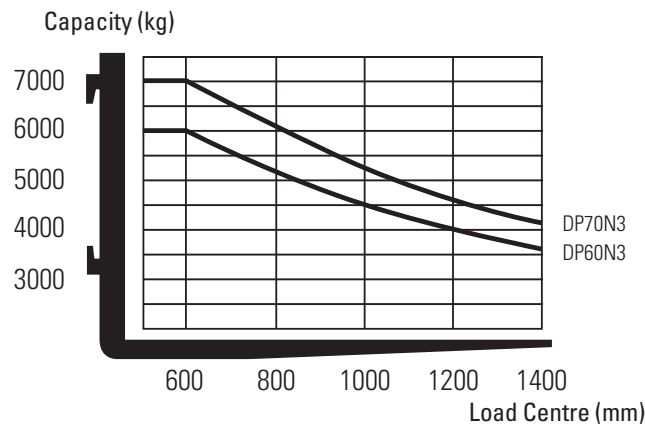

### Mast Performance and Capacity

- h1 Height with mast lowered
- h2 Standard free lift
- h3 Lift height
- h4 Height with mast raised
- h5 Full free lift
- Q Lifting capacity, rated load
- c Load centre (distance)

info@catliftruck.com | www.catliftruck.com

CECSC2155-0(09/21) © 2021 MLE B.V. (registration no. 33274459). All rights reserved. CAT, CATERPILLAR, LET'S DO THE WORK, their respective logos, "Caterpillar Yellow", the "Power Edge" and Cat "Modern Hex" trade dress as well as corporate and product identity used herein, are trademarks of Caterpillar and may not be used without permission.

NOTE: Performance specifications may vary depending on standard manufacturing tolerances, vehicle condition, types of tyres, floor or surface conditions, applications, or operating environment. Trucks may be shown with non-standard options. Specific performance requirements and locally available configurations should be discussed with your Cat lift trucks Dealer. Cat Lift Trucks follows a policy of continual product improvement. For this reason, some materials, options and specifications could change without notice.



Pergudangan Lautan Jaya Kumala, Jl. Inspeksi Kalimalang KM. 22 Blok A Gudang A-01, Cibuntu, Bekasi-17520

Telp : (021) 89535873  
 Mobile : 0817-0555-969  
 Email : thubastunggalperkasa@gmail.com  
 Website : www.thubastunggalperkasa.co.id