

EFL181

1800kg 4-Wheel Li-ion Counterbalance Forklift



- Compact 4 wheels 48V Li-Ion battery truck designed around I/C implemented chassis
- Indoor and outdoor use thanks to the rainproof components and the high ground clearance
- Big diameter wheels to work in every environment
- Great ergonomic design with adjustable steering wheel and comfortable bucket seat
- Powerful AC traction motor
- 48V Li-Ion battery grant efficiency, good autonomy and occasional charge
- Single phase integrated charger with 16A plug



| Manufacturer | | | EP |
|----------------------------------|-------|------|------------|
| Model designation | | | EFL181 |
| Drive | | | Electric |
| Load capacity | Q | kg | 1800 |
| Load center distance | c | mm | 500 |
| Service weight | | kg | 3030 |
| Retracted mast height | h1 | mm | 1995 |
| Lift height | h3 | mm | 3000 |
| Height, mast extended | h4 | mm | 4028 |
| Length to face of forks | l2 | mm | 2015 |
| Overall width | b1/b2 | mm | 1080 |
| Fork dimensions | s/e/l | mm | 40x100x920 |
| Turning radius | Wa | mm | 1920 |
| Travel speed, laden/unladen | | km/h | 8.5/9 |
| Lifting speed, laden/unladen | | m/s | 0.25/0.3 |
| Lowering speed, laden/unladen | | m/s | 0.43/0.45 |
| Max. gradeability, laden/unladen | | % | 10.5/15 |
| Drive motor rating S2 60 min | | kW | 6 |
| Battery voltage/nominal capacity | | V/Ah | 48/150 |



FEATURE

■ On-board charger provides opportunity charging

Due to the usage of Li-Ion technology in combination with an onboard charger, the EFL181 is the most versatile truck you can find on the market. Plug it into any standard power outlet and the battery will be opportunity charged. No need for any external charging device. Just Plug&Play.



■ Compact size

The EFL181 is a very compact truck, while the legroom has been increased for better ergonomics.



■ Entry-level forklift

The EFL181 was designed as a universal forklift for the daily operation at few hours per day. The focus lies on the flexible operation, opportunity charging and worry-free technology of the truck at a great price point.



■ Trustworthy and mature components

EFL181 uses 10-year market tested components, which offers safety and reliability.



Electric Forklift 1.8T

EFL181

| | | | | |
|--------|---|----------------|-------|--------------|
| 1.1 | Manufacturer | | | EP |
| 1.2 | Model designation | | | EFL181 |
| 1.3 | Drive | | | Electric |
| 1.4 | Operator type | | | Seated |
| 1.5 | Load capacity | Q | kg | 1800 |
| 1.6 | Load center distance | c | mm | 500 |
| 1.8 | Load distance, centre of drive axle to fork | x | mm | 405 |
| 1.9 | Wheelbase | y | mm | 1260 |
| 2.1 | Service weight | | kg | 3030 |
| 2.2 | Axle loading, laden front/rear | | kg | 4395/435 |
| 2.3 | Axle loading, unladen front/rear | | kg | 1300/1730 |
| 3.1 | Tyre type | | | Solid rubber |
| 3.2 | Tyre size, front | | | 6.5-10 |
| 3.3 | Tyre size, rear | | | 5.00-8 |
| 3.5 | Wheels, number front/rear (x=drive wheels) | | mm | 2x/ 2 |
| 3.6 | Tread width, front | b10 | mm | 905 |
| 3.7 | Tread width, rear | b11 | mm | 920 |
| 4.1 | Tilt of mast/fork carriage forward/backward | α/β | ° | 6/ 10 |
| 4.2 | Retracted mast height | h1 | mm | 1995 |
| 4.3 | Free lift | h2 | mm | 130 |
| 4.4 | Lift height | h3 | mm | 3000 |
| 4.5 | Height, mast extended | h4 | mm | 4028 |
| 4.7 | Height of overhead guard (cabin) | h6 | mm | 2080 |
| 4.8 | Seat height/standing height | h7 | mm | 1060 |
| 4.12 | Tow coupling height | h10 | mm | 370 |
| 4.19 | Overall length | l1 | mm | 2935 |
| 4.20 | Length to face of forks | l2 | mm | 2015 |
| 4.21 | Overall width | b1/b2 | mm | 1080 |
| 4.22 | Fork dimensions | s/e/l | mm | 40×100×920 |
| 4.23 | A,B Fork carriage class/type A, B | | | 2A |
| 4.24 | Fork carriage width | b3 | mm | 1040 |
| 4.31 | Ground clearance, laden, below mast | m1 | mm | 115 |
| 4.32 | Ground clearance, center of wheelbase | m2 | mm | 120 |
| 4.34.1 | Aisle width for pallets 1000×1200 crossways | Ast | mm | 3525 |
| 4.34.2 | Aisle width for pallets 800×1200 crossways | Ast | mm | 3725 |
| 4.35 | Turning radius | Wa | mm | 1920 |
| 5.1 | Travel speed, laden/unladen | | km/h | 8.5/9 |
| 5.2 | Lifting speed, laden/unladen | | m/s | 0.25/ 0.3 |
| 5.3 | Lowering speed, laden/unladen | | m/s | 0.43/ 0.45 |
| 5.5 | Drawbar pull, laden/unladen | | N | — |
| 5.6 | Max. drawbar pull, laden/unladen | | N | 10000 |
| 5.8 | Max. gradeability, laden/unladen | | % | 10.5/15 |
| 5.10 | Service brake | | | Hydraulic |
| 5.11 | Parking brake | | | Mechanical |
| 6.1 | Drive motor rating S2 60 min | | kW | 6 |
| 6.2 | Lift motor rating at S3 15% | | kW | 7.5 |
| 6.4 | Battery voltage/nominal capacity | | V/Ah | 48/150 |
| 6.5 | Battery weight | | kg | 115 |
| 8.1 | Type of drive control | | | AC |
| 10.5 | Steering design | | | Hydraulic |
| 10.7 | Sound pressure level at the driver's ear | | dB(A) | 70 |

If there are improvements of technical parameters or configurations, no further notice will be given. The diagram shown may contain non-standard configurations.

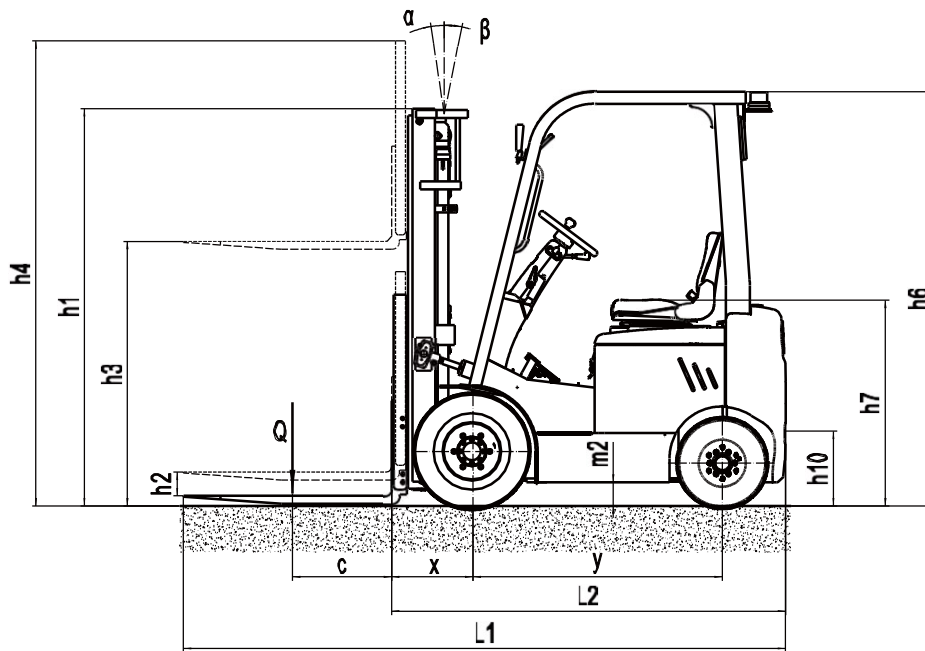
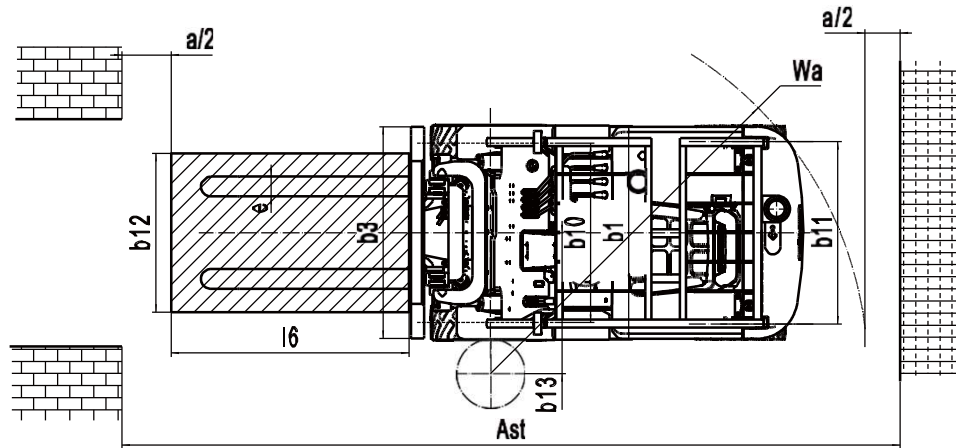

Mast option:

| Mast types | Lift height (h3) | Height, Mast | | | Height,Free lift(h2) | |
|-----------------|-----------------------|-----------------------------|---------------------------|---------------|----------------------|---------------|
| | | Height, mast lowered(h1) | Height, mast extended(h4) | | No shelving | With shelving |
| | | | No shelving | With shelving | | |
| | mm | mm | mm | mm | mm | mm |
| 2-Standard Mast | 2500 | 1745 | 2985 | 3528 | 130 | 130 |
| | 2700 | 1845 | 3185 | 3728 | 130 | 130 |
| | 3000 | 1995 | 3485 | 4028 | 130 | 130 |
| | 3300 | 2145 | 3785 | 4328 | 130 | 130 |
| | 3600 | 2295 | 4085 | 4628 | 130 | 130 |
| 2-Free Mast | 2500 | 1778 | 2985 | 3528 | 1293 | 750 |
| | 2700 | 1878 | 3185 | 3728 | 1393 | 850 |
| | 3000 | 2028 | 3485 | 4028 | 1543 | 1000 |
| | 3300 | 2178 | 3785 | 4328 | 1693 | 1150 |
| 3-Free Mast | 4350 | 2000 | 4844 | 5378 | 1506 | 972 |
| | 4500 | 2050 | 4994 | 5528 | 1556 | 1022 |
| | 4800 | 2150 | 5294 | 5828 | 1656 | 1122 |

RATED CAPACITIES AND LOAD CENTERS GRAPH

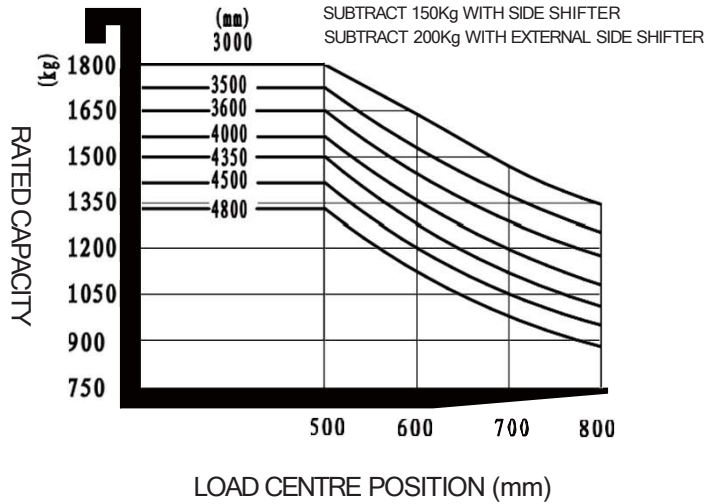

Option:

| No. | Optional items | EFL181 |
|------|----------------------|---|
| 1.1 | Fork dimension | ● 100*40*920○100*40*1070○100*40*1100○100*40*1150 ○ 100*40*1220○100*40*1370○100*40*1520○100*40*1800 |
| 1.4 | Fork carriage width | ● 1068mm○Yes and can be customized |
| 1.5 | Fork carriage height | ● 1028mm○Yes and can be customized |
| 2.5 | Front wheel material | ● solid○Pneumatic○Non-marking tires |
| 2.6 | Rear wheel material | ● solid○Pneumatic○Non-marking tires |
| 2.7 | Battery capacity | ● 48V150AH○48V205AH |
| 2.8 | Charger | ● 48V50A○48V30A |
| 2.10 | Seat type | ● TOYOTA○Suspension |
| 2.11 | Attachments | ● No○Built-in sidershifter○External shifter○Adjustable fork |
| 2.13 | Traction pin | ● Yes |
| 3.5 | Front lamp | ● LED |
| 3.6 | Rear lamp | ● NO○LED |
| 3.7 | Warning lamp | ● Yes |
| 3.8 | Steering lamp | ● Yes |
| 3.9 | Blue lamp | ● NO○Yes and not customized |
| 3.10 | Area warning lamp | ● NO○Yes and not customized |
| 3.11 | Rearview mirror | ● One Rearview mirror○Two Rearview mirror |
| 3.12 | Hummer | ● Yes |
| 3.15 | Fire extinguisher | ● NO○Yes and not customized |
| 3.17 | OPS system | ● NO○Yes and not customized |
| 3.23 | Remote monitoring | ● NO○Yes and not customized |
| 4.3 | Cabin | ● NO○Semi-enclosed cab, front wiper, after wiper,With electric fan |

Note: ● Standard ○ Optional - Inconformity