

ZOOMLION

EXTENDED-RANGE HYBRID TELESCOPIC BOOM LIFT

ZT26JEH-V

Comply with CE Standard



HIGHLIGHTS

- ▶ Safe and reliable lithium battery power system equipped with BMS low-temperature heating and low-temperature charging current control functions improves battery life by 30% and adapts to -20°C cold environment
- ▶ Fast charging technology adapting to complex charging environment, no fear of wide voltage fluctuations, efficiency increased by 20%
- ▶ Wheel side AC drive system, the maximum gradeability can reach 45%
- ▶ Electro-hydraulic system with auto flow controlling, saving energy of 10%
- ▶ Brand-new appearance with lightweight GFRP composite material hood and integrally formed coating features anti-corrosion, heat preservation, aging resistance and easy cleaning
- ▶ Assembled large-opening component box, open-close hood, and a variety of reserved inspection holes easy to service
- ▶ Range extender and battery power system for long working hours; Available fuel or electric powered mode, more fuel efficient than diesel models

FEATURES

Standard Features

Telecommunications System
Horn
Proportional control
All motion alarm
Flashing beacon
Self-closing entry gate
Emergency descent system
Emergency stop button
Auto-leveling system
On-board diagnostic system
Tilt protection system
Oscillating axle
Load sensing system
Remote monitoring and rental management platform

Accessories & Options

- ▶ Platform work light
- ▶ Anti-collision device
- ▶ AC power to platform

ZOOMLION



THUBAS TUNGGAL PERKASA
Make it Better | Your Solutions | Customer is Our Goal

Model	ZT26JEH-V
Size	
Work Height	28.70m
Platform Height	26.70m
Horizontal Outreach	22.1m
A Overall Length (Stowed)	11.91m
B Overall Width (Stowed)	2.49m
C Overall Height (Stowed)	2.82m
D Platform Length	2.44m
E Platform Width	0.91m
F Wheelbase	2.80m
Track width	2.49m
G Ground Clearance	0.41m
Performance	
Platform Capacity	300/454kg
Drive Speed (stowed)	5.5km/h
Gradeability	45%(24°)
Turning Radius (Inside)	3.11m
Turning Radius (Outside)	6.16m
Turntable Rotation	360° continuous
Platform Rotation	±90°
Tail Swing	1.61m
Jib Rotation	130° (-55°~75°)
Max. Wind Speed	12.5m/s
Power	
Battery	80V / 460Ah
Range Extender	8kW
Charger	5kW/80V
Drive Motor	5.2kW
Lift Motor	30kW
Auxiliary power	12V DC
Fuel Tank	105L
Hydraulic Tank Capacity	120L
Tire	
Tire Type	Foam-filled tire Solid tire
Weight	
Gross	17200kg

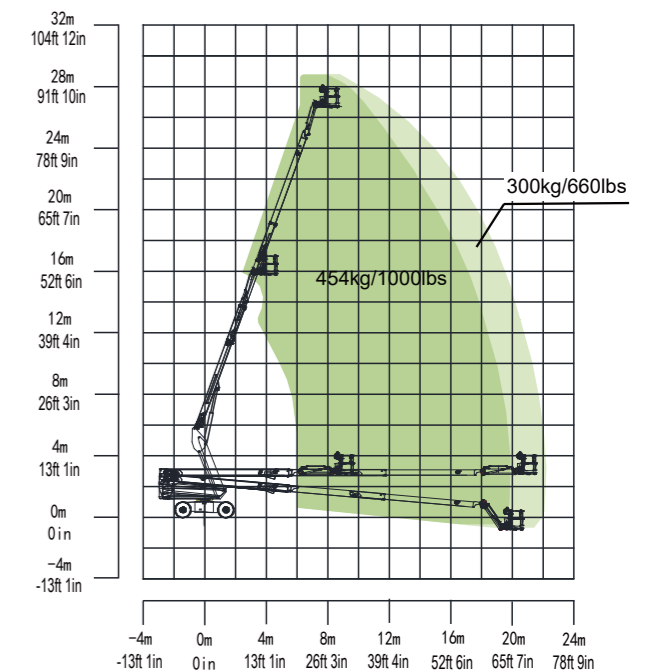
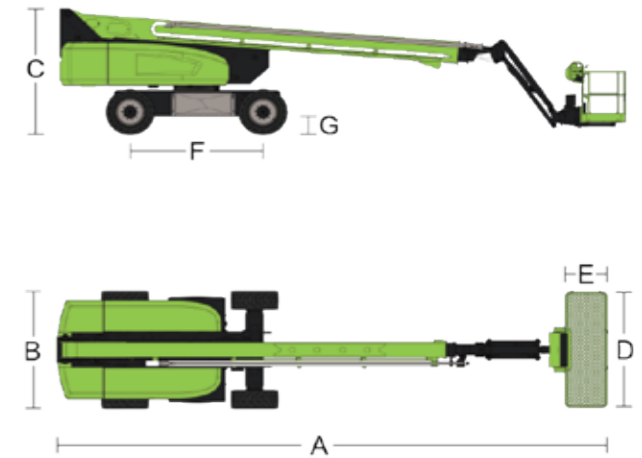

Range of Motion ZT26JEH-V