



X Series Heavy IC Forklift Trucks

with capacities of 14,000 to 18,000kg



Gang Wates Kp. Rawa Banteng No.83 Rt 003/01 Ds Mekarwangi
Kec. Cikarang Barat, Kabupaten Bekasi, Jawa Barat

T : 0877-8445-0249 E : thubastunggalperkasa@gmail.com W : thubastunggalperkasa.co.id

The World of Hangcha



X SERIES HEAVY IC FORKLIFT TRUCKS

The heavy load X series is extension of the new series of internal combustion counterbalance forklift truck developed by Hangcha independently, adopting the world advanced technologies based on the original products. Through the comprehensive upgrading of appearance molding, energy conservation, environmental protection, comfort, security and reliability, it will become the world-class forklift truck which can meet your overall demands.

CHARACTERISTICS

The truck has professional and entirely-new appearance, has great identifiable degree, has simple and smooth profiling and has great industrial aesthetics. The exposed parts are arranged in concealed manner, and the appearance is more concise.

The key parts are products of internationally well-known brands, have been utilized in the products of previous models, have been validated by the market, and are reliable and durable; The modular and standard design is applicable, the main parts are validated in advance and by steps, the truck has great maturity.



Easy/ Efficiency/ Economy



STAGE V & TIER 4F

HANGCHA with you at every stage
Efficient, reliable solutions for your demands

With Hangcha you can meet all Stage V/Tier 4f emissions standards which provides customer demands for value, innovation and performance. The technologies include common rail fuel systems, Turbocharged Inter-cooled selective catalytic reduction (SCR), diesel oxidation catalysts (DOC) and diesel particulate filters (DPF). Designed and optimised to every engine model, our forklift truck maximises efficiency and reliability.

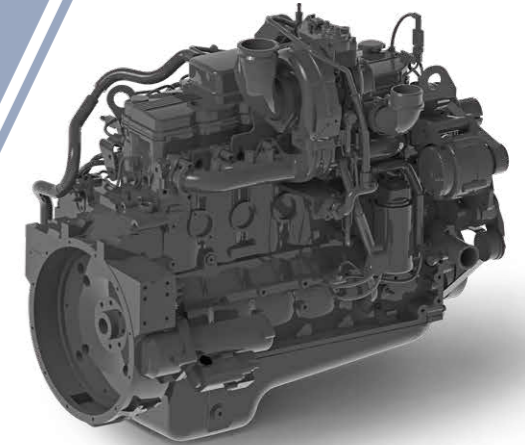

CUMMINS B6.7

High Performance

The performance is improved. The travel speed and lift speed are improved by 10%-20%. The body of the truck is reduced, and the flexibility is strengthened. Thanks to CAE (Computer Aided Engineering) technology, structural components are more balanced.

Comfort

With the new-style fully-suspended and overall-view cab. The profile of the truck is optimized; The vision is more excellent. The interior ornaments are formed, feeling is more comfortable; Shaped steel tube integral frame provides high strength and better sealing.

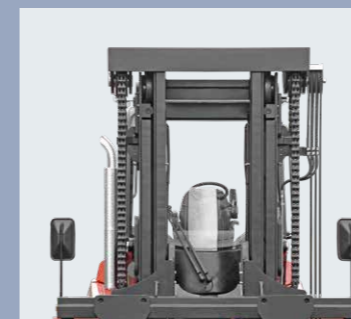
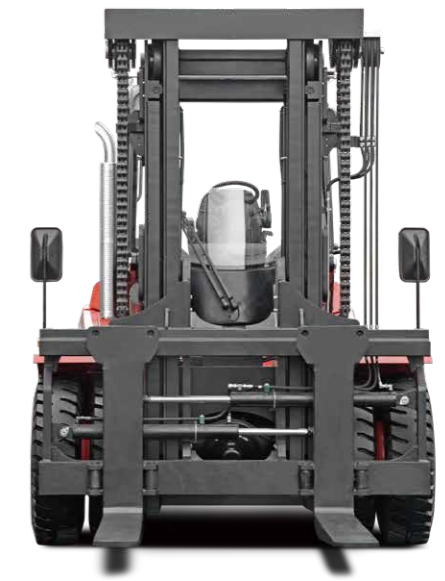

Excellent all round visibility is achieved by the overall design.



Thanks to the unique design, cab can be tilt without any tools, major service items can be reached easily by tilting the cabin, maximized access is possible.



Optional imaging system with front and rear camera, increasing the safety greatly.



ZF gear box with micro-electronic control provides for three-shift power shifting, travelling is stable and accurate.



Load sensing hydraulics provide high efficiency and energy saving, reducing hydraulic oil working temperature and also extending the life of hydraulic components and seals.



Anti-slip pedal provides high safety and easy maintenance.



Battery compartment is easy to open for easy maintenance.



The newly designed LCD instrument has more comprehensive functions and more stable performance. It can display the important information such as truck status and engine faults... So that the operator can understand the truck status more intuitively and facilitate maintenance.



Suspended seat with fingertip system that can be easily adjusted to suit each customer.



KESSLER heavy-duty traction axle, two-stage deceleration; Wet brake, maintenance-free; Hydraulic release spring action parking brake, safe and reliable.



Reliability

Increased digitization, additional central controller, CAN-bus structure, built-in multiple diagnostic, management functions and fault alarm are convenient for diagnosis.

Precise Operation

Integrated fingertip system, pilot control, smart and accurate; Hydraulic brake curve optimization, smooth and easy control.

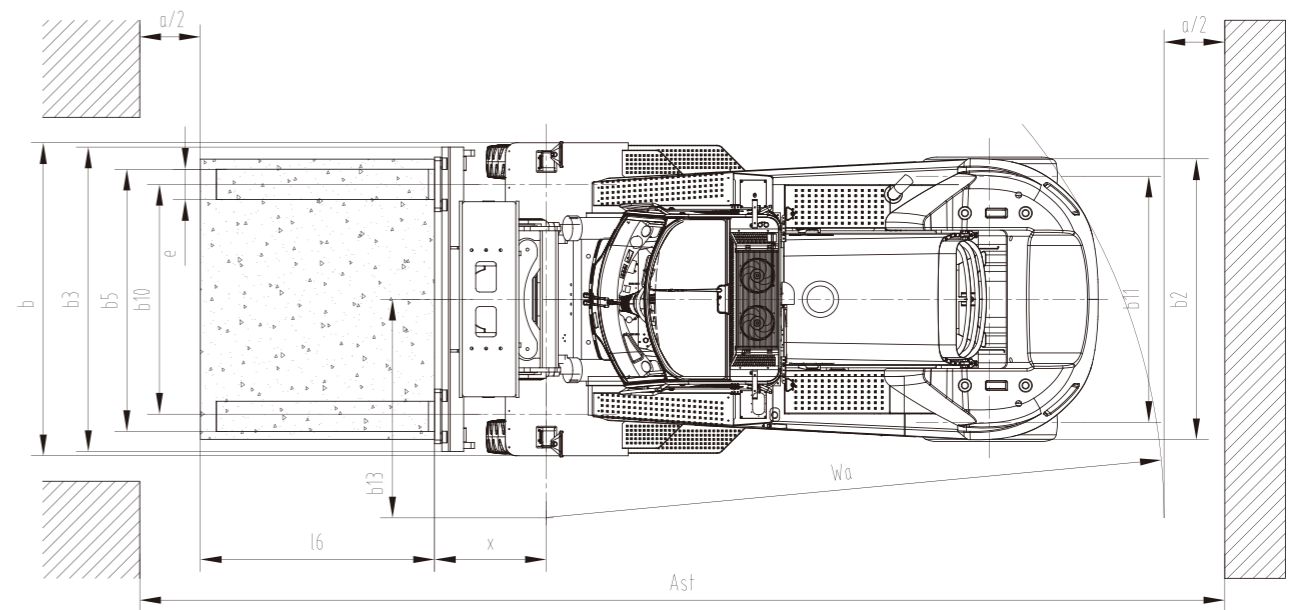
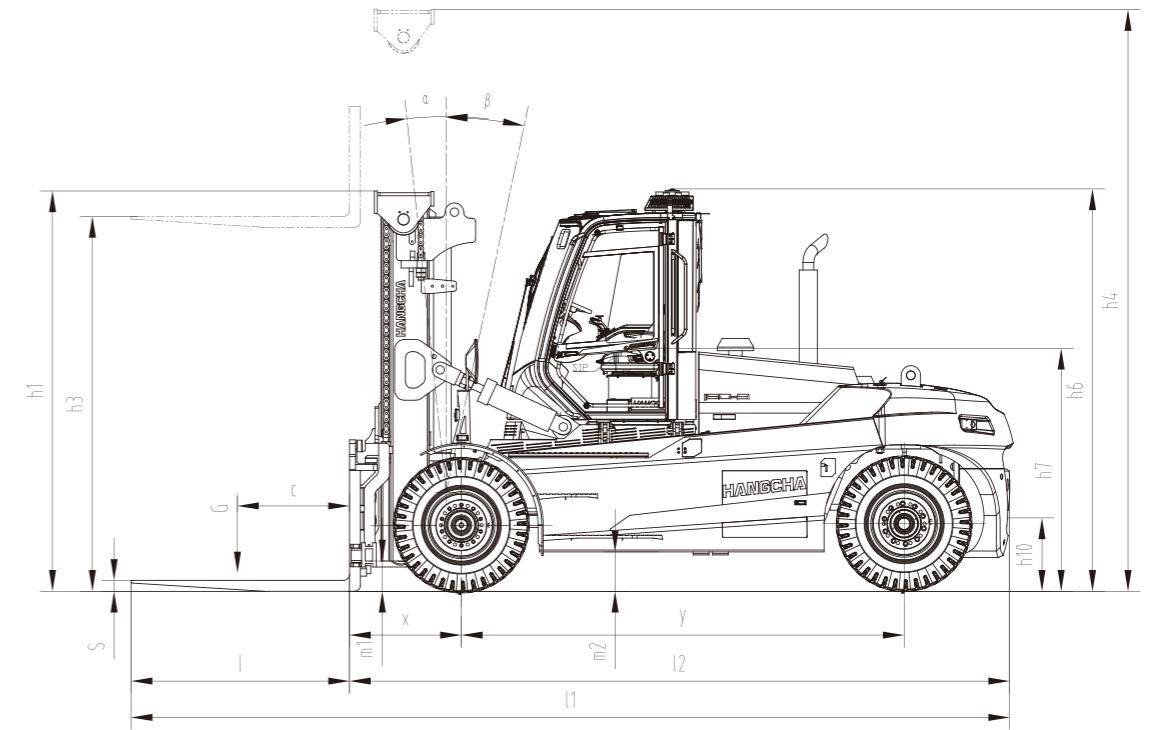
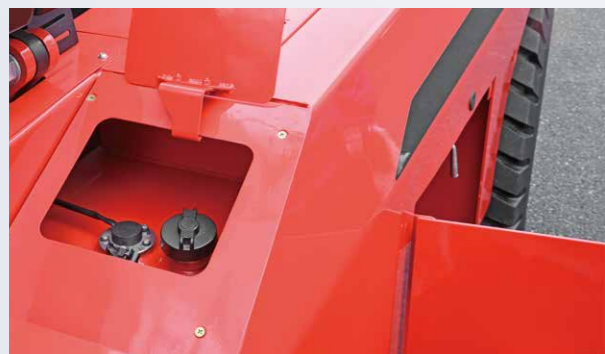

Features

Transmission	Standard	Options
Pneumatic tyre	●	
Solid tyre		○
Steering system		
Fully hydraulic power steering	●	
Centralized lubrication system (machine)		○
Power system		
Extended exhaust pipe	●	
Lockable fuel cap		○
Spark arrester		○
Pre-cleaner air filter	●	
Truck		
Tow pin	●	
Electrostatic discharge chain		○
Rear-view mirror on right & left mudguards	●	
Operating system		
Integrated joystick	●	
Adjustable steering column	●	
Adjustable armrest	●	
Hydraulic system		
Variable hydraulic pump system	●	
Four-way hydraulic valve	●	
Cab		
Cabin	●	
Climate control system (air-conditioning and heater)	●	
Manual tilting cabin	●	
Electric tilting cabin		○
Radio	●	
Sunshade	●	
USB charging interface	●	
Clothes hanger hook	●	
Reading light	●	
1 x 24V power supply		○
1 x 12V power supply		○
License plate frame		○
Fan	●	
Lifting components		
Duplex mast	●	
Standard lifting height	●	
Optional lifting height		○
Standard fork	●	
Other fork specifications		○
Fork hook on type		○
Hydraulic Fork Positioning	●	
Independently-adjustable fork		○
Built in Sideshift	●	
Integrated sideshift		○
Other		
Standard color	●	
User defined colour		○
Fire extinguisher (2kg/4kg)		○
Vehicle toolkit	●	

Electrical System	Standard	Options
Operator Presense System (OPS) with buzzer	●	
LCD display screen	●	
Main power switch	●	
Emergency power off switch	●	
Maintenance-free 24V lead acid battery	●	
Reverse buzzer	●	
High decible horn	●	
LED lights (entire vehicle)	●	
2 x Working light on front mudguard	●	
2 x Front working light on top of cabin	●	
2 x Rear working light on top of cabin		○
2 x Working light on both sides of mast	●	
Reverse sensor	●	
rearview camera system		○
rearview camera system with memory		○
front & rearview camera system		○
front & rearview camera system with memory		○
4 directions camera system with single display		○
4 directions camera recording system with single display		○
In cabin CCTV		○
Rear blue safety light		○
Front and rear blue safety light		○
Three sided blue danger zone light		○
Overspeed alarm		○
Speed limitation		○
Voice reverse alarm		○
Automatic fire suppression system		○
Two-way radio		○
Weight indicator in display	●	
Flashing warning light (non rotating) with control switch		○
Tyre pressure monitoring	●	
On-board diagnostics system	●	
Engine fault alarm	●	
Engine oil pressure alarm indicator	●	
Air filter warning indicator	●	
Water temperature indicator	●	
Hour meter	●	
Battery charge indicator	●	
Low hydraulic pressure alarm indicator	●	
Hydraulic oil filter warning indicator	●	
Oil gauge	●	
Fuel-water separator warning indicator	●	
Oil temperature gauge	●	
Pre-heat indicator	●	
Drive mode indicator	●	
Parking brake indicator	●	
Service indicator	●	

POWERFUL TRUCKS

