



HANGCHA Lithium-ion
⚡ Re-imagining POWER ⚡

A Series Lithium-ion Walkie Straddle Stacker

with capacities of 2,500lbs



Gang Wates Kp. Rawa Banteng No.83 Rt 003/01 Ds Mekarwangi
Kec. Cikarang Barat, Kabupaten Bekasi, Jawa Barat

T : 0877-8445-0249 E : thubastunggalperkasa@gmail.com W : thubastunggalperkasa.co.id

Making Material Handling Easier
SINCE 1956



LET THE LITHIUM POWER TAKE OVER



INNOVATIVE SOLUTIONS NEW POWER NOW

Lithium-ion technology (Lithium Iron Phosphate), was developed by HANGCHA and a leading lithium-ion cell manufacturer for use in material handling equipment applications. These innovative and reliable battery cells and modules are manufactured to the highest standard for HANGCHA's forklift line.

- / **Battery Technology:** We use square Lithium Iron Phosphate cells. These are the same type of batteries used in new electric vehicles.
- / **Design:** The module uses a sturdy steel fram to provide excellent heat dissipation.
- / **Safe and Effective:** Charging efficiency is 93% and the thermal runaway temperature is 572°F.
- / **Adapted to Low Temperatures:** Comes standard with an electrical heating feature, ensuring normal operation in low temperatures.
- / **Efficient:** Can use opportunity charging to allow for continuous use in multi-shift operations.
- / **Long-Lasting:** 4000 charging cycles with a capacity retention greater than 80%.
- / **Maintenance-Free:** Lithium-ion batteries do not require manual maintenance such as watering.
- / **Green and clean:** The batteries are pollution-free, release zero emissions, and are recyclable.

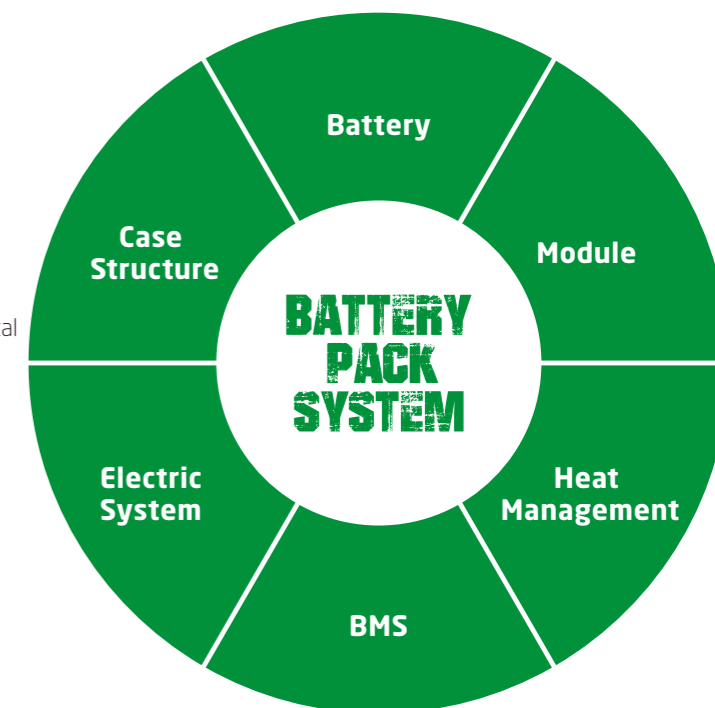

Rapid charging and opportunity charging ensure continuous availability of material handling equipment

This technology allows for fast full charging or boost charging. They are maintenance free and do not require a battery change when used in multi-shift operations.

**LI-ION
TECHNOLOGY**

HANGCHA PROVIDES UP TO A **5 YEAR OR 10,000 HOUR** GUARANTEE ON THE LITHIUM IRON PHOSPHATE BATTERY PACK.



**5 YEAR
WARRANTY**

INDUSTRIAL STRENGTH STACKING

The A Series Lithium-ion Straddle Stacker is a new logistics handling device developed by Hangcha Group for the high-intensity operating conditions of the North American market. With AC drive technology, it offers high performance and low maintenance costs. It is also safe, reliable, and can be easily operated. This is an ideal tool for loading, unloading, and handling palletized goods in warehouses, supermarkets, and workshops.



Appearance

- / The A Series Walkie Straddle Stacker Pallet Truck has a smooth vivid profile and was designed to be ergonomic. The exterior of this forklift is powder coated in a durable, easy to see, green finish that designates it as a lithium-ion powered pallet truck.
- / This pallet truck uses stamped steel plates and injection molded parts. This creates a robust and durable product that is able to successfully take on the wear and tear of a warehouse environment.

High Performance

- / The maintenance-free, high-power, brushless AC traction motor has excellent acceleration, performance, good climbing ability, and low heat generation.
- / The CURTIS control system provides accurate, stable, and more efficient control of the AC traction motor.
- / The CANBUS structure makes the communication between the different parts on the truck faster and more reliable.
- / The truck uses the regenerative braking system to prevent the pallet truck from sliding down a ramp.
- / The hydraulic pump, switches, controller, connectors, and battery plug are all parts from industry known suppliers to ensure reliability, performance, and ease of service.

Reliability

- / The electrical system uses water-proof plugs and connectors to increase reliability and provide protection to the walkie straddle stacker's electronics.
- / The non-contact proximity switch features a long service life and is reliable.
- / The low noise and vibration hydraulic power unit enables stable and reliable lifting and lowering.
- / The punched formed forks provide higher strength and are impact resistant.
- / The pallet truck is equipped with tip guides to improve operational efficiency.
- / The power plug is fastened to the stacker's body. This prevents the plug from being damaged due to impact when the lithium-ion battery is lifted for installation.

Lithium Iron Phosphate Battery Pack

- / Integrated Battery Management System (BMS) continually monitors energy management and ensures reliable operation.
- / HANGCHA provides these Lithium Iron Phosphate (LiFePO₄) battery packs with up to a 5 year or 10,000 hour warranty.
- / See warranty certificate for specific warranty information on the Lithium Iron Phosphate battery packs.

Standard Battery Capacity	
Battery Capacity (V/Ah) (kW-h)	25.76V/150Ah 3.86kW-h
Charger	Built-in (25.76V/40A)

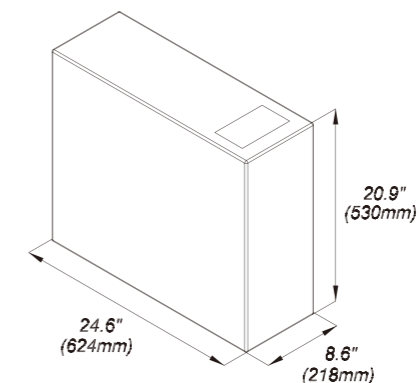

Features a Built-in 40A Charger and Maintenance-Free Battery.



The compact body and rounded design give the pallet truck an ideal footprint for operation in narrow spaces.



The pump motor's controller offers proportional lowering. This gives the operator precise control and stability when lowering goods.



Fixed Straddle Baselegs (Inside Dimension in 4" increments from 38" to 50") Optional adjustable baselegs fit a wide range of pallet sizes.

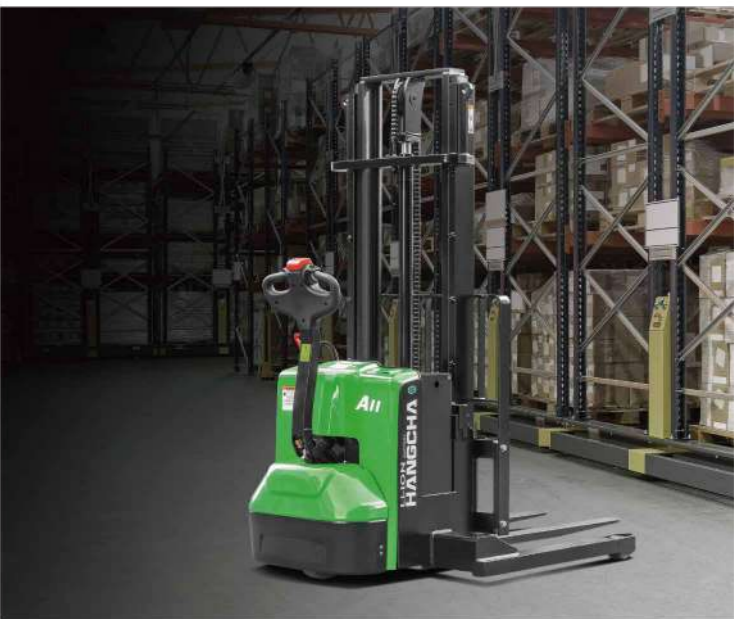

Standard Specifications

- / 25.76 Volt Electrical System
- / CANBUS Communication
- / Curtis AC Controller
- / PU Drive Tire
- / Maintenance-Free Lithium-ion Battery
- / Built-in 40A Charger
- / SB-175 Red Battery Connector
- / Battery Disconnect Handle
- / Key Switch
- / Multi-Function Meter
- / Electric Horn
- / Upright-Tiller Creep Speed Feature
- / PU Load Wheel
- / Single Load Wheel
- / 40" Load Backrest Height

Options

- / Load Backrest
- / PIN Code Access
- / Adjustable Width Base Legs
- / 2 Stage Mast 78-141" (2-3.6m)
- / Wire Mesh Mast Screen

Safety

- / Travel speed is automatically reduced when fork is lifted above 19.5"
- / The power plug is fixed on the truck body to avoid damage when installing the battery.
- / The pallet jack won't slip on a grade to ensure safe operation.
- / When pressed, the emergency button on the tiller head immediately cuts power to the pallet truck to help keep the operator safe.
- / The lifting limit switch is designed to help protect loads from damage.
- / The pallet jack features a soft landing system to protect goods from being damaged.

Maintenance

- / The brushless AC drive motor is maintenance-free. This significantly reduces the operating costs of the pallet truck.
- / The integrated battery indicator, hour meter and self-diagnostic instrument are all easy to use.
- / The maintenance hatch opens to allow for easy access to all of the truck's components.

Comfort

- / Thanks to the tiller's design, all operations can be completed with one hand.
- / When in turtle mode, the truck can be driven slow easily, and more accurately.
- / The pallet truck's design is optimized for great visibility and easy operation in narrow aisle applications.

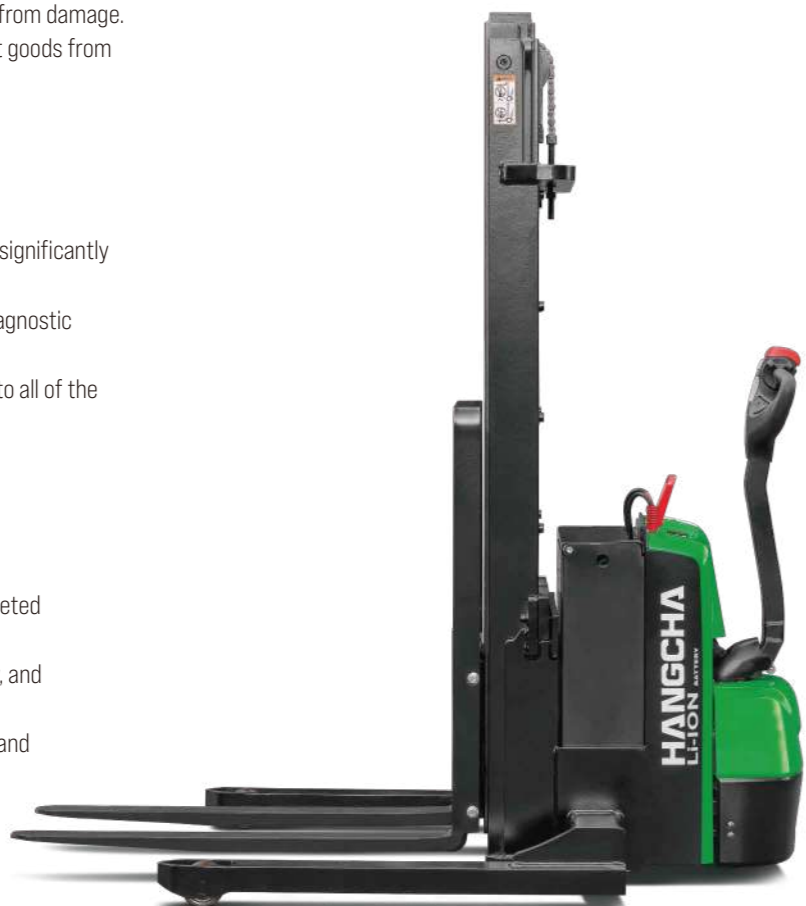

A Series Lithium-ion Walkie Straddle Stacker Specification

Distinguishing Marks	11	Manufacturer	HANGCHA GROUP CO.,LTD.			
		HCFA Model	WSS1MLi			
Weight	12	Manufacturer's Type Designation	CT011-AC1-2NAI			
	14	Operator Type: hand, pedestrian, standing, seated, order-picker	Walkie			
	1.5	Rated Capacity/Rated Load	Q (lb/kg)	2500/1130		
	1.6	Load Centre Distance	c (in/mm)	24/600		
	1.8	Load Distance, centre of drive axle to fork	x (in/mm)	22/570		
	1.9	Wheelbase	y (in/mm)	50/1260		
	21	Service Weight Without Battery	lb/kg	1920/871		
Tires & Chassis	3.1	Tires: solid rubber, superelastic, pneumatic, polyurethane	PU			
	3.2	Tire size, front	in/mm	Φ9-3/Φ230-75		
	3.3	Tire size, rear	in/mm	Φ4×2.75/Φ100×70		
	3.4	Additional Wheel (dimensions)	/			
	3.5	Wheels, number front / rear (x = driven wheels)	1x*/2			
	3.6	Tread, front	b ₀ (in/mm)	/		
	3.7	Tread, rear	b ₁ (in/mm)	46/1170		
Dimensions	4.2	Height, mast lowered	h (in/mm)	81/2050		
	4.4	Lift	h ₀ (in/mm)	118/3000		
	4.5	Height, mast extended	h ₄ (in/mm)	140/3550		
	4.10	Height of Wheel Arms	h _e (in/mm)	4/100		
	4.15	Fork Height, lowered	h _s (in/mm)	1.4/35		
	4.19	Overall Length	l (in/mm)	77/1958		
	4.20	Length to Face of Forks	l ₂ (in/mm)	35/887		
	4.21	Overall Width	b ₁ /b ₂ (in/mm)	28/50 (710/1270)		
	4.22	Fork Dimensions	s/e/l (in/mm)	1.4/3.9/42 (35/100/1070)		
	4.25	Distance between Fork-Arms	b ₂ (in/mm)	8.3-31.1 (210-790)		
	4.26	Distance between Wheel Arms	b ₄ (in/mm)	42/1070		
	4.32	Ground Clearance, centre of wheelbase	m ₂ (in/mm)	1.57/40		
	4.35	Turning Radius	W _a (in/mm)	57.4/1457		
4.37	Length across Wheel Arms	l ₁ (in/mm)	62/1566			
Performance Data	5.1	Travel Speed, laden/unladen	mph (kph)	3.7/3.7 (6/6)		
	5.2	Lift Speed, laden/unladen	ft/min (m/s)	23/36 (0.115/0.185)		
	5.3	Lowering Speed, laden/unladen	ft/min (m/s)	39/39 (0.2/0.2)		
	5.8	Max Gradeability, laden/unladen	%	10/16		
Electric Motor	6.1	Drive Motor Rating S2 60 min	hp/kW	1.74/1.3		
	6.2	Lift Motor Rating at S3 5%	hp/kW	2.95/2.2		
	6.4	Battery Voltage, rated capacity	V/Ah	25.76/150		
8.1	Type of Drive Control	AC				
9.1	Controller Manufacturer	CURTIS				

Mast

Mast Type	Max. Lifting Height h ₃		Ground Clearance, Fork (h ₂ +h ₃)		Lowered Height h ₁		Extended Height h ₄ without Load Backrest		Free Lift		Load Capacity at 24" (600mm)	
	in	mm	in	mm	in	mm	in	mm	in	mm	lb	kg
Single Cylinder Duplex Mast	78	2000	80	2035	61	1550	100	2550	5.3	135	2500	1135
	98	2500	100	2535	71	1800	120	3050	5.3	135	2500	1135
	106	2700	108	2735	75	1900	128	3250	5.3	135	2500	1135
	118	3000	119	3035	81	2050	140	3550	5.3	135	2200	1000
	130	3300	131	3335	87	2200	152	3850	5.3	135	2000	907
	137	3500	139	3535	94	2385	163	4135	5.3	135	1800	816
Single Cylinder Full-Free Mast	141	3600	143	3635	96	2435	167	4235	5.3	135	1600	725
	98	2500	100	2535	71	1800	120	3050	28.5	724	2500	1135
	106	2700	108	2735	75	1900	128	3250	32.4	824	2500	1135
	118	3000	119	3035	81	2050	140	3550	38.3	974	2200	1000
	130	3300	131	3335	87	2200	152	3850	44.2	1124	2000	907
	137	3500	139	3535	94	2385	163	4135	51.5	1309	1800	816
Single Stage Mast	141	3600	143	3635	96	2435	167	4235	53.5	1359	1600	725
	53	1350	54.5	1385	75	1900	75.4	1915	32.5	825	2500	1135
	59	1500	60.4	1535	81	2050	81.3	2065	38.4	975	2500	1135
69	1750	70.2	1785	94	2385	94.5	2400	51.8	1310	2500	1135	

Aisle Guide

Aisle Requirement for Right Angle Stack ①

Load Width		Load Length					
		in(mm)	36(914)	40(1016)	42(1067)	44(1117)	48(1219)
	30(762)	in(mm)	80.5(2044)	80.5(2044)	82.0(2083)	83.6(2123)	87.0(2209)
	32(813)	in(mm)	80.5(2044)	81.1(2061)	82.7(2100)	84.2(2139)	87.6(2224)
	36(914)	in(mm)	80.5(2044)	82.5(2095)	83.9(2132)	85.4(2169)	88.6(2250)
	40(1016)	in(mm)	82.4(2095)	83.9(2132)	85.3(2167)	86.7(2203)	89.8(2281)
	42(1067)	in(mm)	82.4(2095)	84.8(2153)	86.1(2186)	87.4(2220)	90.4(2296)
	44(1117)	in(mm)	84.4(2143)	85.5(2171)	86.8(2204)	88.1(2239)	91.1(2313)
	48(1219)	in(mm)	86.3(2193)	87.1(2212)	88.3(2243)	89.6(2275)	92.4(2347)

① Add a minimum of 12in (300mm) for maneuverability.

